

**T.R.**  
**NECMETTİN ERBAKAN UNIVERSITY**  
**INSTITUTE OF EDUCATIONAL SCIENCES**  
**DEPARTMENT OF ENGLISH LANGUAGE TEACHING**

**FOREIGN LANGUAGE ANXIETY IN RECEPTIVE LANGUAGE**  
**SKILLS IN ELT CLASSROOMS AT**  
**NECMETTİN ERBAKAN UNIVERSITY**

**Mehmet KARACA**

**Master of Arts Thesis**

**Advisor**  
**Asst. Prof. Dr. Fahrettin ŞANAL**

**Konya-2012**

**T. C.**  
**NECMETTİN ERBAKAN ÜNİVERSİTESİ**  
**Eğitim Bilimleri Enstitüsü Müdürlüğü**

**BİLİMSEL ETİK SAYFASI**

Öğrencinin	Adı Soyadı	Mehmet KARACA
	Numarası	105218021004
	Ana Bilim / Bilim Dalı	Yabancı Diller Eğitimi/ İngiliz Dili Eğitimi
	Programı	Tezli Yüksek Lisans <input type="checkbox"/> Doktora <input type="checkbox"/>
	Tezin Adı	Foreign Language Anxiety in Receptive Language Skills in ELT Classrooms at Necmettin Erbakan University



Bu tezin proje safhasından sonuçlanmasına kadarki bütün süreçlerde bilimsel etiğe ve akademik kurallara özenle riayet edildiğini, tez içindeki bütün bilgilerin etik davranış ve akademik kurallar çerçevesinde elde edilerek sunulduğunu, ayrıca tez yazım kurallarına uygun olarak hazırlanan bu çalışmada başkalarının eserlerinden yararlanılması durumunda bilimsel kurallara uygun olarak atıf yapıldığını bildiririm.

Öğrencinin imzası  
(İmza)

T. C.  
NECMETTİN ERBAKAN ÜNİVERSİTESİ  
Eğitim Bilimleri Enstitüsü Müdürlüğü  
YÜKSEK LİSANS TEZİ KABUL FORMU

Öğrencinin	Adı Soyadı	Mehmet KARACA
	Numarası	105218021004
	Ana Bilim / Bilim Dalı	Yabancı Diller Eğitimi/ İngiliz Dili Eğitimi
	Programı	Tezli Yüksek Lisans
	Tez Danışmanı	Asst. Prof. Dr. Fahrettin ŞANAL
Tezin Adı	Foreign Language Anxiety in Receptive Language Skills in ELT Classrooms at Necmettin Erbakan University	

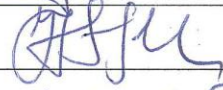
Yukarıda adı geçen öğrenci tarafından hazırlanan “Foreign Language Anxiety in Receptive Language Skills in ELT Classrooms at Necmettin Erbakan University” başlıklı bu çalışma 03.../08.../2012 tarihinde yapılan savunma sınavı sonucunda oybirliği/oyçokluğu ile başarılı bulunarak, jürimiz tarafından yüksek lisans tezi olarak kabul edilmiştir.

Ünvanı, Adı Soyadı	Danışman ve Üyeler	İmza
Yrd. Doç. Dr. Fahrettin ŞANAL	Danışman	
Yrd. Doç. Dr. Hakan SİNİR	Üyeler	
Yrd. Doç. Dr. Hasan YICMAZ	Üyeler	

## ACKNOWLEDGEMENT

I would like to express my thanks to those who had helped me through with my thesis. The first person that I would like say thanks to is my thesis advisor Asst. Prof. Dr. Fahrettin Sanal, for his substantial advice, encouragement, and guidance. My heartfelt thanks go to my mentors, Assoc. Prof. Dr. Hasan Cakir, Asst. Prof. Dr. Harun Simsek, Asst. Prof. Dr. Ece Sarigül, and Asst. Prof. Dr. Abdülhamit Çakır, for their support and practical feedback on my thesis. I would like thank my friends, Res. Asst. Seyit Ahmet Çapan and Res. Asst. Galip Kartal, for their support and help during administering the questionnaires. Without their assistance I would not have been able to finish them.

I owe special thanks to Asst. Prof. Dr. Ahmet Oğuz Aktürk and Alper Torun, for their substantial contributions in statistical analyses of my thesis.

More special thanks go to Kurtis Allan for his generous help for reviewing the literature review part of my thesis.

I would like to thank all my colleagues and friends, especially Fikri Köken and Sabri Uzuner, for their encouragement and invaluable comments throughout the writing process of this thesis.

Additional thanks go to the participants who shared their feelings with me and spent their invaluable time for this study.

Finally, I would like to express my deepest gratitude to my wife, Hacer Karaca and my son, M. Taha Karaca for their constant support, encouragement and patience throughout the writing process of this thesis.

## ÖZET

Bu çalışma Türk İngiliz Dili Eğitimi öğrencilerinin algılayıcı dil becerilerindeki dil kaygısını araştırmıştır. Bu çalışmanın amaçları (a) Türk İngiliz Dili Eğitimi öğrencilerinin algılayıcı dil becerileri kaygısını (yabancı dil okuma kaygısı ve yabancı dil dinleme kaygısı) ne miktarda tecrübe ettiklerini, (b) öğrencilerin yabancı dil okuma kaygısı ile yabancı dil dinleme kaygısı seviyeleri arasındaki ilişkiyi, (c) öğrencilerin algılayıcı dil becerileri kaygısının cinsiyet ve üniversite yılları açısından farkını, (d) okuma ve dinleme kaygısına katkı sağlayan faktörleri ve (e) öğrencilerin kaygısını azaltmaya yardımcı olan faktörleri incelemektir. Bu hedefler için, Necmettin Erbakan Üniversitesi İngiliz Dili Eğitimi bölümünde farklı sınıflardan toplam 159 İngilizceyi yabancı dil olarak öğrenen öğrencinin katılımıyla hem nicel hem de nitel veri toplama yöntemlerini içeren bu betimsel çalışma gerçekleştirildi. Nicel veri için öğrenciler yabancı dil okuma kaygı ölçeği ve yabancı dil dinleme kaygı ölçeğini doldurdular. Nitel veri için yabancı dil okuma kaygı ölçeği ve yabancı dil dinleme kaygı ölçeği puanları esas alınarak her sınıftan 3 erkek ve 3 kız olmak üzere toplanan 18 yüksek kaygılı öğrenci geçmişleri ile ilgili anketi doldurduktan sonra mülakat için davet edildiler. Yabancı dil okuma kaygı anketi ve yabancı dil dinleme kaygı anketi ile toplanan veriler ANOVA, T-Test ve Pearson Product - Moment korelasyon analiz yöntemleriyle analiz edildi.

Bulgular öğrencilerin orta seviyede okuma ve dinleme kaygısına sahip olduklarını ortaya çıkardı. Öğrencilerin dinleme kaygı seviyeleri okuma kaygı seviyelerinden biraz daha yüksektir. Okuma kaygısı ile dinleme kaygısı arasında orta derecede pozitif bir ilişki vardır. Ayrıca, sonuçlar ikinci sınıftaki öğrenciler ve üçüncü sınıftaki öğrenciler arasında eğitim yılları ile okuma kaygısı arasında orta seviye bir ilişki olduğunu ortaya koydu. Şöyle ki, ikinci sınıftaki öğrencileri okuma kaygısı üçüncü sınıftaki öğrencilerin okuma kaygılarından daha yüksek bulundu. Ayrıca, birinci sınıflar açısından hem okuma hem de dinleme becerilerinde anlamlı bir cinsiyet farkı vardı. Kız öğrenciler erkek öğrencilerden hem okuma kaygısı hem de dinleme kaygısı bakımından daha kaygılıydılar.

Okuma ve dinleme kaygısının ana kaynağı öğrencinin kendisidir. Bundan başka, hata ve yanlış yapma korkusu, öğretmenin hata düzeltme ve geri dönüt verme tavrı, okuma/dinleme parçasının konusu, okuma/dinleme sürecindeki sınıf içi aktiviteler, konuşmacının konuşma tarzı gibi durumlar okuma ve dinleme kaygısının diğer muhtemel nedenleridir. Kaygıyı azaltma yollarına gelince, öğrenciler öğrencinin kendisi, zihinsel ve duyuşsal stratejiler ve olumlu bir sınıf ortamı oluşturma üzerinde yoğunlaştılar.

## ABSTRACT

This study explored the language anxiety in receptive language skills of Turkish ELT learners. The purposes of the study were to investigate (a) to what extent Turkish ELT students experience receptive language skills anxiety (foreign language reading and foreign language listening anxiety), (b) the relationship between foreign language reading anxiety and foreign language listening anxiety levels of the learners, (c) the difference between the students' receptive language skills anxiety in terms of their gender and academic status, (d) the factors that contribute their reading and listening anxiety, and (e) the factors that may help to reduce their anxiety. For these aims, this descriptive study including both quantitative and qualitative data collection methods was conducted in the ELT Department of Necmettin Erbakan University with the participation of 159 EFL learners from three different grade levels (freshman, sophomore, and junior). The students took the foreign language reading anxiety scale (FLRAS) and foreign language listening anxiety scale (FLLAS) for quantitative data. Based on their FLRAS and FLLAS scores, a total of 18 highly anxious students (3 male and 3 female students from each grade) were invited to interview followed by a background questionnaire for qualitative data. The data gathered from FLRAS and FLLAS was analyzed by ANOVA, T-Test and Pearson Product - Moment Correlation analysis methods.

The findings identified that the students had a moderate level of reading and listening anxiety. Their levels of listening anxiety were slightly higher than those of reading anxiety. There was a moderate positive correlation between reading anxiety and listening anxiety. Moreover, results revealed a moderate relationship between education level and reading anxiety among sophomores and juniors. That is, reading anxiety levels of sophomores were found to be higher than those of juniors. Next, there was a significant difference in terms of gender on reading and listening skills regarding freshmen. Female students were more anxious than male students in terms of reading anxiety and listening anxiety.

The learner characteristics were the main source of reading and listening anxiety. Apart from this, fear of failure and making mistake, the instructor's manner of error correction and giving feedback, topic of the reading/listening text, the classroom activities in reading/listening process, speech of the interlocutor were potential sources of reading and listening anxiety. As for the ways of reducing anxiety, the learners emphasized the learner characteristics, cognitive and affective strategies, and creating a positive classroom environment.

**Abbreviations**

ELT: English Language Teaching

EFL: English as a Foreign Language

FLRAS: Foreign Language Reading Anxiety Scale

FLLAS: Foreign Language Listening Anxiety Scale

ESL: English as a Second Language

FL: Foreign Language

L2: Second Language

US: United States

FLCAS: Foreign Language Classroom Anxiety Scale

L1: First Language

FLLA: Foreign Language Listening Anxiety

TCs: Teacher Candidates

LSC: Learning Skills Center

KPSS: Kamu Personeli Seçme Sınavı

## List of Tables

Table 1. Reading processes	45
Table 2. Descriptive statistics of the participants in terms of academic status	55
Table 3. Descriptive statistics of the participants in terms of gender	55
Table 4. Descriptive statistics for the FLRAS	57
Table 5. Descriptive statistics for the FLLAS	58
Table 6. Descriptive statistics for the FLRAS and FLLAS	64
Table 7. The Pearson's $r$ correlation between reading and listening anxiety levels	65
Table 8. The results of the independent samples $t$ -test of male vs. female differences on the FLRAS scores	66
Table 9. The results of the independent samples $t$ -test of male vs. female differences on the FLLAS scores	66
Table 10. Differences in terms of gender on reading and listening anxiety among freshmen	67
Table 11. Differences in terms of gender on reading and listening anxiety among sophomores	67
Table 12. Differences in terms of gender on reading and listening anxiety among juniors	68
Table 13. Descriptive statistics of reading and listening differences on academic status	69
Table 14. ANOVA results of FLRAS and FLLAS according to students' academic status	69
Table 15. The sources of the differences between reading and listening anxiety in terms of academic status	70
Table 16. Descriptive statistics of the first interview question	73
Table 17. Descriptive statistics of the second interview question	74
Table 18. Descriptive statistics of the third interview question	74
Table 19. Descriptive statistics of the fourth interview question	75
Table 20. Descriptive statistics of the fifth interview question	76
Table 21. Descriptive statistics of the sixth interview question	76

Table 22. Descriptive statistics of the seventh interview question	77
Table 23. Descriptive statistics of the eighth interview question	78
Table 24. Descriptive statistics of the ninth interview question	78
Table 25. Descriptive statistics of the tenth interview question	79
Table 26. Descriptive statistics of the eleventh interview question	80
Table 27. Descriptive statistics of the twelfth interview question	80
Table 28. Descriptive statistics of the thirteenth interview question	81

**List of Figures**

Figure 1. The relationship between anxiety and performance	13
Figure 2. A model of the effects of anxiety on learning from instruction	19
Figure 3. Competitiveness and the second language learner	25
Figure 4. The role of gender on receptive language skills	65
Figure 5. The role of grade level on receptive language skills	68

**List of Appendices**

Appendix 1.Foreign Language Reading Anxiety Scale	113
Appendix 2.Foreign Language Listening Anxiety Scale	114
Appendix 3.Background Information Questionnaire	116
Appendix 4.Semi-Structured (Fixed-response) Interview Questions	117

**Contents**

Bilimsel Etik Sayfası	i
Tez Kabul Formu	ii
Acknowledgement	iii
Özet	iv
Abstract	vi
Abbreviations	viii
List of Tables	ix
List of Figures	xi
List of Appendices	xii

**CHAPTER I**

<b>1. INTRODUCTION</b>	1
1.1. Statement of the Problem	4
1.2. The Importance and Purpose of the Study	4
1.3. Research Questions	6
1.4. Hypotheses of the Study	6
1.5. Scopes of the Study	7
1.6. Limitations of the Study	7
1.7. Definitions of the Terms	8

**CHAPTER II**

<b>2. REVIEW OF LITERATURE</b>	10
2.1. What is Anxiety?	10
2.1.1. Trait Anxiety	11
2.1.2. State Anxiety	11
2.1.3. Situation-specific Anxiety	11
2.1.4. Facilitative Anxiety vs. Debilitative Anxiety	12
2.2. Foreign Language Anxiety	14
2.2.1. Components of FL Anxiety	15
2.2.1.1. Communication Apprehension	15
2.2.1.2. Test Anxiety	16
2.2.1.3. Fear of Negative Evaluation	16
2.2.2. Effects of FL Anxiety	17
2.2.2.1. Academic Effects of FL Anxiety	18
2.2.2.2. Cognitive Effects of FL Anxiety	19
2.2.2.3. Social Effects FL Anxiety	20
2.2.2.4. Personal Effects of FL Anxiety	20
2.2.3. FL Anxiety and Learner Variables: Gender and Academic Status	21
2.2.4. Sources of FL Anxiety	23
2.2.5. Ways of Reducing FL Anxiety	32
2.2.6. FL Anxiety and Language Skills	38
2.2.6.1. FL Anxiety and Productive Skills	39
2.2.6.1.1. FL Anxiety in Speaking Skill	39
2.2.6.1.2. FL Anxiety in Writing Skill	42
2.2.6.2. FL Anxiety and Receptive Skills	44

2.2.6.2.1.FL Anxiety and Reading Skill	45
2.2.6.2.2. FL Anxiety and Listening Skill	50
<b>CHAPTER III</b>	
<b>3. METHODOLOGY</b>	54
3.1. Research Design	54
3.2. Participants	54
3.3. Instruments	56
3.3.1. Foreign Language Reading Anxiety Scale	56
3.3.2. Foreign language Listening Anxiety Scale	57
3.3.3. Background Information Questionnaire	58
3.3.4. Semi-Structured (Closed and Fixed-response) Interviews	58
3.4. Data Collection Procedure	60
3.5. Data Analysis	61
<b>CHAPTER IV</b>	
<b>4. RESULTS OF THE STUDY</b>	63
4.1. Analysis of the Research Question 1	64
4.2. Analysis of the Research Question 2	65
4.3. Analysis of the Research Question 3	65
4.4. Analysis of the Research Question 4	71
4.5. Analysis of the Research Question 5	79
4.6. Analysis of the Background Information Questionnaire	81
<b>CHAPTER V</b>	
<b>5. DISCUSSION AND CONCLUSIONS</b>	83
5.1. Discussion	83
5.2. Pedagogical Implications	94
5.3. Suggestion for Future Research	95
5.4. Conclusions	96
<b>REFERENCES</b>	98
<b>APPENDICES</b>	113
Appendix 1	113
Appendix 2	114
Appendix 3	116
Appendix 4	117
<b>CV</b>	119

## CHAPTER I

This chapter begins by presenting an introduction about the importance of learning a language and as a background of the study. It is followed by statement of the problem, and then importance and purpose of the study. Next, research questions generated for this study and hypotheses of the study are placed. After giving brief information on the scope of the study, the terms that may sound unfamiliar to the readers take place.

### 1. INTRODUCTION

“The person, who speaks one language is worth one person,  
The person, who speaks two languages is worth two people.”- *Arabic Proverb*

"Whoever is not acquainted with foreign languages knows nothing of his own." - *Johann Wolfgang von Goethe, German poet*

"A different language is a different vision of life." - *Federico Fellini, Italian film director.*

“Learn a new language and get a new soul.” - *Czech Proverb*

The four statements above express the significance of learning at least one language other than one’s native language. As we live in a dynamic world, learning/knowing a new language puts someone one step further to keep up with this globalized world. For this reason, learning a language is a must and need rather than an interest or a hobby. For example, (a) a new language means a new dimension and horizon, (b) learning a language means learning a new culture, and (c) a new language means a good/ high income job.

For Rivers’ famous book (1981: 8), there are seven classes of objectives in teaching another language:

- ✓ to develop the students' intellectual powers through the study of another language,
- ✓ to increase the students' personal culture through the study of the great literature and philosophy to which the new language is the key,
- ✓ to increase the students' understanding of how language functions and to bring them, through the study of another language, to a greater awareness of the functioning of their own language,
- ✓ to teach students to read another language with comprehension so that they may keep abreast of modern writing, research, and information,
- ✓ to give students the experience of expressing themselves within another framework, linguistically, kinetically, and culturally,
- ✓ to bring students to a greater understanding of people across national barriers, by giving them a sympathetic insight into the ways of life and ways of thinking of the people who speak the language they are learning,
- ✓ to provide students with the skills that will enable them to communicate orally, and to some degree in writing, in personal or career contexts, with the speakers of another language and with people of other nationalities who have also learned this language.

The number of people learning a language, especially English- the global language of this globalized world, is increasing day by day. In Turkey, even if it is mostly learnt for instrumental/pragmatic benefits like to find a good job, to communicate with foreigners, to pass the class, to develop career, etc., English is a compulsory course from primary school (4<sup>th</sup> class) to studying in university. Depending on the types of the school and branch, it is in the curriculum of every school. Within this period, it is intended that the learners should become skillful at language skills; listening-comprehension, reading-comprehension, speaking, and writing, are able to communicate in target language, and have a positive attitude to foreign language teaching (Regulations of Ministry of National Education, Title 5). However, it is not that easy. Learning and teaching English in EFL context countries like Turkey is more challenging when compared to ESL context countries.

There are two potential reasons of this. Firstly, as it is known, a language has both productive (speaking and writing) and receptive skills (reading and listening). As speaking practices and activities are limited, receptive skills; reading and listening activities are the main source of input in Turkey (Köroğlu, 2010). However, unfortunately, those skills are not taken into account seriously. Secondly, even if the skills are involved in the curriculum, the students do the reading and listening activities on their own without knowing almost any of the strategies.

One of the most effective ways in developing a language especially in EFL context countries is to provide as much authentic input (oral and written) as possible. In the same way, Krashen (1982: 7) states that “the best methods are therefore those that supply 'comprehensible input' in low anxiety situations, containing messages that students really want to hear.” This stresses the importance of receptive skills in improving a foreign/second language. Again, Long (1986) has stated that if the receptive skills are well developed, the students will be more confident in language learning. By suggesting language instructors to promote confidence in students' ability to comprehend all kinds of input from the early stages of language instructions, Rivers (1981) has just focused on this.

Even though the required input is evenly provided, some are more successful than other people. The prime mover of this difference between learners in learning English is that there are significant factors in language learning process. Learning a language includes not only cognitive factors; encoding, storage, retention, and retrieval, but also consists of social factors; age, gender, academic status, cooperativeness, competitiveness, classroom environment, etc., and affective factors; motivation, attitude, anxiety, etc. One of the most important affective factors in language learning process is foreign language anxiety. For success in learning and teaching a language all of these factors should be taken into account. Concordantly, according to a research conducted by EF English Proficiency Index carried on in 2011, Turkey is on the 43<sup>rd</sup> rank out of 44 countries. In view of this situation, it is of crucial to name and reveal the factors obstructing to learn a language and to find solutions these problems. Having as a primary goal to raise this awareness, this study

will pay attention to the social factors like age, gender, academic status, etc. and foreign language anxiety in receptive skills will be the main concern of it.

### **1.1. Statement of the Problem**

In Turkey, as a foreign language context, target language input is relatively of prime importance. According to the Input Hypothesis (Krashen, 1982), reading and listening skills are the only ways of providing this comprehensible input for second / foreign language proficiency. Nevertheless, these receptive skills aren't taught appropriately or even if they are being, due to the different learner characteristics like affective (emotional), cognitive, and metacognitive factors, the learners of a foreign language hardly improve these skills (Horwitz, 2008).

To be successful in teaching or learning a foreign language, the factors having impact on language learning should be kept in mind. In this respect, making the learners be highly motivated, low anxious and receptive to language input are our essential purpose. To do this, first and foremost step is to create awareness of language anxiety in receptive skills. Next, to get more comprehensive and in-depth information on receptive skills anxiety, interviews have been conducted. Interviews provide us "back-up data designed to illuminate and explain results obtained from quantitative data" (Peacock, 1998: 12). Interviewing with the learners is important to get precise results on language anxiety as they personally experience foreign language anxiety.

Another major step for an effective teaching or learning of a language is identifying the possible sources, manifestations of foreign language anxiety, and ways of reducing it. Obtaining these from the individuals exposed to language anxiety is another "must" in foreign language teaching or learning. By this way, we will reach more reliable and accurate data on this subject.

### **1.2. The Importance and Purpose of the Study**

First of all, the glass should be filled before it overflows. From this standpoint, the learners should be provided with enough and comprehensible input to produce

something in foreign language. As it is known to all oral production is the major aim in foreign language education. However, especially in foreign language countries like Turkey, the learners of a foreign language have limited opportunities to practice in language. Only way out is therefore to attach particular importance to the receptive skills; reading and listening as they are readily available in FL context.

In this respect, this study has been conducted in hopes of providing more quantitative and qualitative data to the study of foreign language anxiety. This study has both theoretical significance and pedagogical implications. By providing conclusive evidence for the sources and ways of reducing it, this study may make a great contribution to the foreign language literature.

First and foremost reason conducting this study is to create awareness of FL anxiety in ELT departments and guide further research about this concept. In terms of instructors, by identifying the nature, effects, and possible sources of reading and listening anxiety, this study will make instructors be able to get ready for it, behave appropriately, support their students accordingly by modifying the curriculum, teaching techniques, and materials. In terms of the students, they mostly feel alone with language anxiety and compare themselves with other students in order to learn whether the others experience such a feeling or not. If the students realize that language anxiety is a widely common phenomenon in the foreign language classrooms, they will behave more maturely and constructively.

As a last but not least, even though there is a great number of research on productive skills, language anxiety on receptive skills has been drawn quite little attention. There is a common assumption that language anxiety is connected with language production skills; speaking and writing, but it doesn't have such an effect on the comprehension skills; reading and listening. Contrary to the common sense that only production skills are adversely affected by language anxiety, this study will reveal that receptive skills can also be harmed by language anxiety.

### **1.3. Research Questions**

The present study aims at identifying degrees of foreign language reading anxiety and foreign language listening anxiety experienced by Turkish ELT students majoring at Selçuk University. Furthermore, it searches for how the learner variables; gender and academic status relate to reading and listening anxiety, how the students cope with language anxiety, and sources and manifestations of anxiety. Focusing on the results, it will present some possible reasons and solutions for the types and levels of anxiety. With this intention, this study is conducted in the guidance of the following research questions:

1. To what extent do Turkish ELT students experience receptive language skills anxiety (foreign language reading and foreign language listening anxiety)?
2. Is there a relationship between foreign language reading anxiety and foreign language listening anxiety levels of the students?
3. Is there a statistically significant difference between the students' receptive skills anxiety in terms of their gender and academic status?
4. Which factors do students believe contribute to anxiety?
5. Which factors do students believe may help to reduce anxiety?

### **1.4. Hypotheses of the Study**

1. Contrary to the common sense that only production skills are adversely affected by language anxiety, this study will reveal that language anxiety harms the receptive language skills.
2. As both are receptive skills, there will be no significant difference between language anxiety in reading skill and listening skill in terms of students' language anxiety levels. However, the students may have higher levels of listening anxiety than reading anxiety as the former one was mostly neglected in many schools.

3. There will be a relationship between gender and reading/listening anxiety. Female students will have higher levels of reading and listening anxiety than male students.

4. There will be a negative correlation between language anxiety in reading and listening classes and students' academic status. That is, the first-year students will have higher levels of anxiety than the second and third year students.

### **1.5. Scopes of the Study**

The present study is limited to an ELT context. Participants of it are the first, second, and third year students majoring in English as a foreign language in Faculty of Education in Selçuk University. The fourth year students aren't included in this study as they aren't enough in number to participate the study. Next, the conclusions can't be generalized to the whole learners of English as a foreign language. This study aims at revealing the level and types of anxiety regarding gender and academic status. Moreover, the possible sources and manifestations of language anxiety and ways of lessening of it are presented.

Both quantitative and qualitative methods are used as a research framework. Two anxiety scales, namely FLRAS and FLLAS are employed to identify the level and types of anxiety of the learners. For more in-depth information on this subject matter, interviews are carried out as a qualitative research instrument. The instruments to collect data are limited to these.

### **1.6. Limitations of the Study**

Even though the findings of the current study have provided rich insights into foreign language learners' receptive skills anxiety and possible sources and reducing ways of it in terms of the learners' perspectives, this study has several limitations. First, as the participants were only from English Language Teaching Department of Konya NE University, the number of them was to some extent limited. Therefore, it is difficult to generalize the results of this study to all ELT departments in Turkey. The ratio between males and females is another limitation regarding the participants.

The homogeneity of the groups may affect the reliability and validity of the results negatively.

Second, another limitation stems from the measurements employed in the present study. Since the data in this study were gathered primarily through self-report questionnaires, the validity and accuracy of the findings depended on the learners' own beliefs, perception, and willingness to respond to the items. Also, they would have difficulty perceiving some abstract terms if they did not come across these terms before.

### **1.7. Definitions of the Terms**

***English as a Foreign Language (EFL/FL):*** Oxford (2001: 359) defines as “a foreign language as a language being studied in an environment where it is not the primary vehicle for daily interaction and where input in that language is restricted.”

It is defined in the *Longman Dictionary of Language Teaching and Applied Linguistics* (Richards and Schmidt, 2002: 206) as “a language which is not the native language of large numbers of people in a particular country or region, is not used as a medium of instruction in schools, and is not widely used as a medium of communication in government, media, etc. foreign languages are typically taught as school subjects for the purpose of communicating with foreigners or for reading printed materials in the language.”

***English as a Second Language (ESL/L2):*** In *Longman Dictionary of Language Teaching and Applied Linguistics* (2002: 472), it is “in a broad sense, any language learned after one has learnt one's native language. However, when contrasted with foreign language, the term refers more narrowly to a language that plays a major role in a particular country or region though it may not be the first language of many people who use it. For example, the learning of English by immigrants in the US or the learning of Catalan by speakers of Spanish in Catalonia is a case of second language learning.”

***Receptive (comprehension) skills:***The receptive skills are known as “listening” and “reading”. In these skills, learners just receive, identify, decode, and understand a spoken oral written message, not produce anything.

***Productive (expressive) skills:***Speaking and writing are known as “productive skills” whereby the learners produce something in orally or written. They are also called as “active skills”. That is, the learners are active to produce.

## CHAPTER II

### 2. REVIEW OF LITERATURE

This chapter reviews of the literature on foreign language anxiety. It will first present language anxiety and its types; trait, state, situation-specific, debilitating, and facilitative anxieties as general. Then, foreign language anxiety and its components; communication apprehension, test anxiety, and fear of negative evaluation are explained. Later on, effects of foreign language anxiety including academic, cognitive, social, and personal effects are presented. Having discussed the effects of FL anxiety on gender and academic status, the researcher has addressed sources and reducing ways of FL anxiety. Lastly, FL anxiety and language skills; speaking, writing, reading, and listening have discussed. Especially receptive language skills; reading and listening skills have been focused on.

#### 2.1. What is Anxiety?

The effects of anxiety in language learning process have been investigated since the last decades of the 1900s. Even if methods and techniques have been developed substantially in teaching, this phenomenon is still the case in second and foreign language process. There is not a single definition of anxiety as it is a multi-dimensional and complex phenomenon.

For Scovel (1991: 18) anxiety is “a state of apprehension, a vague fear that is only indirectly associated with an object.” Another definition suggested by Spielberger, it is “subjective feeling of tension, apprehension, nervousness and worry associated with an arousal of the autonomic nervous system” (1983: 15). By stating “a threat to some value that the individual holds essential to his existence as a personality”, May (1977: 205) bases anxiety on one’s personality.

In literature, there are mostly two approaches in terms of classification/categorizing anxiety. The former includes trait, state, and situation anxiety (MacIntyre and Gardner, 1991a); the latter consists of debilitating and facilitating anxiety (Alpert & Haber, 1960).

### **2.1.1. Trait Anxiety**

This type of anxiety causes the learners to suffer from anxiety even if they are familiar with the situations or not. The ones who have trait anxiety feel anxious about a great deal of things consciously or unconsciously. To MacIntyre, “it is a stable predisposition to become anxious in a wide range of situations” (1995: 93). Mostly it is stated as “personality trait” (Eysenck, 1979; Oxford and Ehrman, 1993, Spielberger, 1983). It arises from “emotional instability” (Goldberg, 1993). Due to their personal characteristics, the learners with trait anxiety are sensitive to a variety of situations. Similarly, Spielberger (1966: 16) suggests that it is “acquired behavioral disposition that predisposes an individual to perceive a wide range of objectively nondangerous circumstances as threatening.”

### **2.1.2. State Anxiety**

It is called state anxiety when the learners are exposed to the apprehension over a certain time period as a reaction to certain situation. It affects the learner for a short period of time in that it is not durable and can change in the course of time. State anxiety “varies in intensity and duration and fluctuates over time as a function of the amount of stress that impinges upon an individual and that individual’s interpretation of the stressful situation as personally dangerous or threatening” (Spielberger, 1976: 5). For MacIntyre (1995: 93), “it is an immediate, transitory emotional experience with immediate cognitive effects.” Become anxious before an examination is a good picture of this kind of anxiety (Spielberger, 1983). Assertively, Allwright and Bailey express that foreign language anxiety is a kind of state anxiety which is peculiar to the foreign language classroom (1991).

### **2.1.3. Situation-specific Anxiety**

It is the anxiety which is specific to a certain situation over a period of time. MacIntyre and Gardner (1994b: 2) states that “it can be considered to be the probability of becoming anxious in a particular type of situation, such as during tests (test anxiety), when solving mathematics problems (math anxiety), or when speaking a second language (language anxiety).” This type of anxiety is related to trait anxiety (personality) except that the former is experienced in a well-defined

situation (MacIntyre & Gardner, 1991a) like taking a test, speaking before a public, solving math problems, attending in a language class, etc. and the latter is permanent and shows a general tendency to become anxious in any situation (Casado & Dereshiwsky, 2001; Scovel, 1978; Spielberger, 1972). Furthermore, situation-specific anxiety differs from the state anxiety in that situation-specific anxiety takes place more likely in academic situations.

Foreign language anxiety is a type of situation specific anxiety where the anxiety is specific to language learning situations like speaking before the students, listening to the teacher, trying to comprehend a message, etc. (Horwitz, Horwitz & Cope, 1986). On the other hand, Oxford (1999: 62) states that “language anxiety starts as transitory episodes of fear in a situation of performing in the language, it diminishes over time . . . but if it does not decrease, it becomes a trait and will affect language learning pervasively.”

#### **2.1.4. Facilitative Anxiety vs. Debilitative Anxiety**

Based on its effects on one's language learning performance, some researchers (Alpert & Haber, 1960; Kleinmann, 1977; Scovel, 1978) have approached language anxiety as facilitative (helpful anxiety) and debilitative anxiety (harmful anxiety).

If the anxiety affects the learning in a positive way; makes the students more concentrated and motivated and cope with the high-pressured process of language, it is called as “facilitative anxiety”. Oxford thinks it a positive kind of anxiety which increases motivation and performance (1999). Language anxiety at reasonable level provides the learners stand in the process of language learning in terms of cognitive and affective alertness (Spielmann & Radnofsky, 2001). Krashen has claimed that “anxiety has a positive effect on language learning not on language acquisition” (cited in Young, 1992: 160). Related to facilitative anxiety, Kleinmann (1977) found that the students experiencing anxiety tended to use difficult grammatical structures in speaking and writing skills. Next, Bailey's (1983) study of competitiveness and anxiety has revealed that facilitating anxiety takes place when the competitiveness motivates the learners to study for the language in second language learning. On the

other hand, Horwitz (1990) has argued that in language learning, there is no such thing as facilitating anxiety, and that all anxiety in this setting will probably be debilitating because language learning is such a multifarious and psychologically intricate phenomenon.

As for the “debilitative anxiety”, it is a phenomenon which harms learning and causes a loss of performance in language learning. In the same vein, Oxford claims that it is a negative kind of anxiety which causing to lose motivation and performance (1999). On this twofold issue, Scovel (1978: 139) discusses that;

Facilitating anxiety motivates the learner to ‘fight’ the new learning task; it gears the learner emotionally for approach behaviour. Debilitating anxiety, in contrast, motivates the learner to ‘flee’ the new learning task; it stimulates the individual emotionally to adopt avoidance behaviour.

Figure 1. The relationship between anxiety and performance

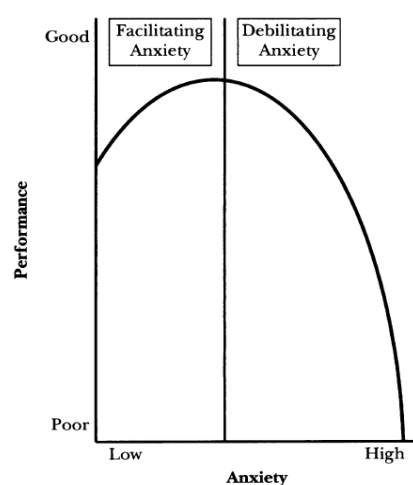

This figure (extracted from MacIntyre, 1995: 92) shows the relationship between anxiety and performance. It is called “facilitative anxiety” when the anxiety is low and so the performance increases while it is called “debilitative anxiety” when the anxiety is high and so the performance decreases. Both of them may be experienced by a learner at the same time (Scovel, 1978). Accordingly, Alpert and Haber expresses that “an individual may possess a large amount of both anxieties, or of one but not the other, or of none of either” (1960: 123).

In conclusion, even though there are a number of researchers (Horwitz, Horwitz & Cope, 1986; Matsuda & Gobel, 2004; MacIntyre & Gardner, 1989; Young, 1991) claiming that anxiety debilitates the learning issue, some others (Campbell & Ortiz, 1991; Oxford, 1999; Scovel, 1991; Alpert & Haber, 1960) who claim that anxiety may facilitate the performance in some conditions.

## 2.2. Foreign Language Anxiety

Even if investigated and discussed for years, foreign language anxiety still occupies the language education agenda. Moreover, the studies on language anxiety are increasing all around the world day by day. However, the results of the studies on this issue are inconsistent and conflictive. This arises from the complexity and multidimensionality of language anxiety. Sellers states that “anxiety is a complex psychological construct consisting of many variables; therefore, it is difficult to collapse all these variables into a single concise definition (2000: 512). Relatedly, Young (1991: 426) states that;

The problem with much of the research was that the relationship between anxiety and language learning/performance could not be viewed without taking into account as assortment of variables, such as language setting, anxiety definitions, anxiety measures, age of subjects, language skill, and research design.

Due to these various variables, the results of the studies conducted on language anxiety differ from each other. While some have discovered negative relationship between anxiety and achievement, several others have discovered positive relationship between them. What’s more, there are several studies showed no relationship at all. For Scovel (1978), one of the reasons of that inconsistency is researchers’ not clearly stating the type of anxiety that they try to measure. One other reason of these inconsistent results is using general measures of anxiety (Gardner and MacIntyre, 1993a). Therefore, to define and measure language anxiety is the first and foremost step in language anxiety context.

Foreign language anxiety is a kind of anxiety experienced by the learners of a foreign language while they are learning a language. Horwitz and associates describe anxiety as “a distinct complex of self-perceptions, beliefs, feelings, and behaviors related to classroom language learning arising from the uniqueness of the language learning process” (1986: 128). For Oxford (1999: 59), language anxiety “is fear or apprehension occurring when a learner is expected to perform in the second or foreign language.” MacIntyre and Gardner (1994: 284) maintained that it is “the

feeling of tension and apprehension specifically associated with second language contexts, including speaking, listening, and learning.”

They were Horwitz, Horwitz, and Cope (1986) who measured language anxiety in general in a comprehensive and organized way by using a special instrument; Foreign Language Anxiety Scale (FLCAS). This questionnaire is the first and most commonly used instrument in the language anxiety context as it shows high validity and high internal reliability. The measurement investigates participants' communication apprehension, test-anxiety and fear of negative evaluation; and focuses on speaking in a classroom context. This instrument aims at measuring the amount and type of anxiety experienced by the foreign language students in a classroom context.

### **2.2.1. Components of FL Anxiety**

According to Horwitz et al. (1986) as a “situation-specific anxiety”, language anxiety had three related performance anxieties, namely *communication apprehension*, *test anxiety*, and *fear of negative evaluation*. Nonetheless, language anxiety isn't limited to only these three components because of its complexity.

#### **2.2.1.1. Communication Apprehension**

It is a kind of anxiety which arises when the learners experience difficulty in expressing their thoughts or ideas to other students (Brown, 1980). The learners experiencing this kind of anxiety are shy of communicating not just in a public but in most situations. It arises mostly in “public speaking” or “stage fright”; performing in front of an audience. For Horwitz et al. (1986) it stems from the students' knowledge that they will almost certainly have difficulty in understanding and being understood. Accordingly, speaking and listening are the major activities that cause communication apprehension in the language learning environment. For MacIntyre and Gardner (1991a), “fear of negative evaluation” is closely related to communication apprehension. Because of this fear, the learners may not show their real performance in front of the teacher and their peers. In the same way, perfectionism and competitiveness may trigger the communication apprehension.

### **2.2.1.2. Test Anxiety**

Evaluation is one of the most important stages in the process of language learning. Due to the fact that the learners of a language commonly have tests, quizzes, and exams, they experience a kind of performance anxiety. The fear of “failing to perform well” especially in oral tests is known as test anxiety. This type of performance anxiety is based on the evaluation process of language learning. To Saranson (1984, cited in Aida, 1994) it is “the tendency to view with alarm the consequences of inadequate performance in an evaluative situation”. Some students can’t show their real performance in exams even though they have that ability. Another definition made by Zeidner (1998) on this kind of performance anxiety is “anxiety subjectively relating to taking tests and exams, including anxiety related to the threat of failing an exam and the associated negative consequences”.

Grading students by traditional means of evaluation has always been argued as causing poor performance in education for many students.

### **2.2.1.3. Fear of Negative Evaluation**

It is the fear of being judged by others; teacher and friends in the classroom environment. On this issue, Young (1991) found that the students who were afraid of saying wrongly were unwilling to take place in the activities. For Watson and Friend (1969, cited in Horwitz et al., 1986: 128), it is “apprehension about others’ evaluations, avoidance of evaluative situations and expectations that others would evaluate oneself negatively.” In this respect, this kind of apprehension may arise from student’s comparing each other’s in terms of some assets. They maintain that this anxiety differs from test anxiety as it isn’t limited only to the test situations. By addresses this anxiety as a personality trait, Kitano (2001) found that fear of negative evaluation was a source of anxiety in the Japanese FL classroom. Aida (1994: 157) proclaims that “students experiencing this anxiety sit passively in the classroom, withdrawing from classroom activities that could otherwise enhance their improvement of the language skill”.

### 2.2.2. Effects of FL Anxiety

Researchers have some difficulty in demonstrating the role of anxiety in FL learning. Even if there are a number of empirical studies demonstrating the relationship between anxiety and achievement for years, some questions still remain to be answered. The results are inconsistent and even confusing. The reason of this confusion is using various instruments to measure different kinds of anxiety (Phillips, 1992). She maintained that language differences, age of participants, language skills to be evaluated, proficiency levels of learners, and methodology are all variables causing confusion. To give some examples, Rodriguez (1995) conducted one of his studies on the relationship between FLCAS scores and final grades by using Spanish-speaking pre-service teachers and discovered a significant negative correlation. Merç (2010) also carried on his study among 450 Turkish student teachers to find out the level and sources of foreign language student teaching anxiety throughout their teaching practicum and to investigate the relationship between language proficiency level and the level of foreign language anxiety. One of the findings of his study in terms of the relationship between proficiency and anxiety is that there is no significant relationship between language proficiency and foreign language student teacher anxiety. Sertçetin (2006) conducted her study among Turkish primary school students; 5<sup>th</sup> and 8<sup>th</sup> class students to investigate classroom foreign language anxiety. To conduct a survey with 125 English majors, Wang (2010) adopted English listening tests and questionnaire to measure English listening classroom anxiety at the university level.

Under these circumstances, some studies show a negative effect of anxiety on learning while some others show positive effect. More interestingly, several other studies have found no effect of anxiety on learning. For example, Chastain (1975) found that the learners in a French audio-lingual class had higher grades when their anxiety level was low, on the other hand, there was a positive relationship state anxiety and achievement in Spanish classes. MacIntyre and Gardner (1989) found significant negative correlations between a specific measure of language anxiety (French class anxiety) and performance on a vocabulary learning task. Aida (1994) found a significant negative correlation between FLCAS scores and final grades

among American second-year Japanese students. By revealing that FL anxiety can have a negative impact on Japanese learners' performance, Saito and Samimy's study (1996) replicated the studies above. Contrary to the studies above, Kleinmann (1977) found a positive association between test anxiety and using target grammatical structures of the learners. Young (1991) found no relationship between anxiety and oral proficiency. Similarly, Backman (1976) also found no association between language anxiety and achievement.

In his review of literature, MacIntyre (1999) classified the effects of language anxiety into four main categories; academic, cognitive, social, and personal effects.

#### **2.2.2.1. Academic Effects of FL Anxiety**

These effects include low test scores, course grades, and therefore overstudying. There exist several studies investigating and indicating the relationship between language anxiety and academic achievement in language courses. Phillips (1992) discovered that students experienced more anxiety tended to receive lower exam grades. Similarly, in a study of Canadian university learners of French Coulombe (2000) found a somewhat smaller (but significant) negative correlation between FLCAS scores and final grades in eleven French classes ranging from beginning to advance. On the one hand, Horwitz et al. (1986: 131) express that "some students may experience an anxious reaction of such intensity that they postpone required foreign language courses until the last possible moment or change their major to avoid foreign language study." While some cut the class and postponing their homework, some others overstudy.

In his affective filter hypothesis, Krashen (1985) asserted that high anxiety prevents comprehensible input and this in turn makes the learners less responsive to input. That is, the learners of a foreign language can't adopt the desired learning practices and competence in language. One of the possible results of lack of enough comprehensible input is difficulty discriminating the sounds and structures and grasping the content of a target language message (Horwitz, 1986). Also, the learners may use simpler, more concrete, and impersonal sentences to interpret on a topic.

### 2.2.2.2. Cognitive Effects of FL Anxiety

These effects are related to acquisition, retention, production, perception, comprehension, rehearsal, retrieval, and thinking problems. For instance, in testing situations, learning is impeded by language anxiety in that learners may forget or can't remember the required grammatical points because of stress or nervousness. Tobias (1986) proposed a model of the effects of anxiety on learning a language.

Figure 2.A model of the effects of anxiety on learning from instruction (cited in Young, 1999: 35)

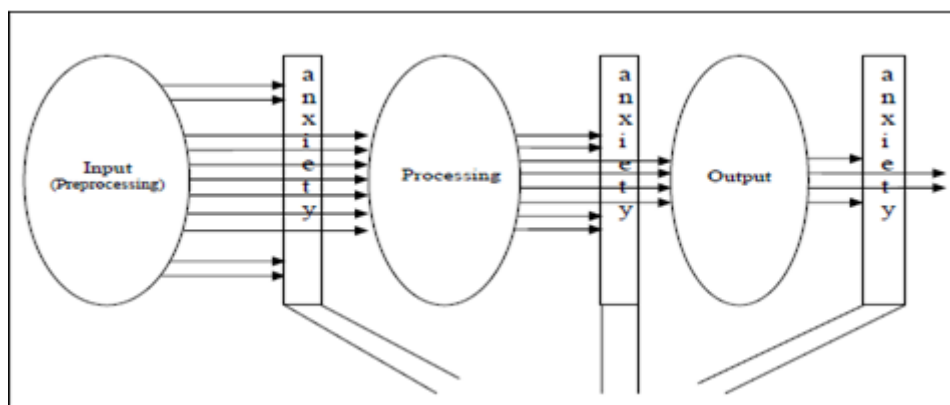

To this model, anxiety interferes learning at three stages; input, process, and output. The figure above shows the relationship between anxiety and the stages of language learning.

In input stage, anxiety may emerge as attention deficits. Anxious learners can't easily concentrate on and involve in the course. Or, even if they do, it doesn't last for a long time. Next, in this stage, the students experience some memorization problems in that they can't memorize and retain a new word or phrase in the target language. Decoding the message in listening and reading classes is also the effect of anxiety. Shortly, anxiety acts a filter at this stage. In process stage, the learners build up the knowledge after they take in from the input stage. Anxiety at this stage emerges by preventing storing newly input knowledge. The last stage is output stage in which the learnt and stored knowledge is put in performance. It is also called as production stage. The students are required to produce something orally or written.

Accordingly, language anxiety mostly interferes learning in process and output stages. Anxious students can't demonstrate their real performance even though they are capable of. Learners experience difficulty speaking in front of a group or in the language classroom. Because of this they can't express themselves clearly. It manifests as speaking anxiety or communication apprehension at this stage. MacIntyre and Gardner (1994) claimed that anxiety had different effects on the input, process, and output stages. There is a negative correlation between foreign language anxiety and both input stage and output stages. However, anxiety is a significant variable on the process stage.

### **2.2.2.3. Social Effects FL Anxiety**

These are the effects which mostly arise out of negative and competitive classroom environment. For this reason, anxious students are less likely to volunteer to answer and participate in the classroom activities. According to MacIntyre and Charos (1995, cited in Bekleyen, 2004), the learners experiencing higher anxiety are less willing to communicate and they speak rarely. As aforementioned, the students who were afraid of saying wrongly were unwilling to take place in the classroom activities (Young, 1991). Similarly, Aida claims that socially effected students sit passively and withdraw from classroom activities (2004). This is because; they too lack the motivation to involve the class. Another study conducted by Steinberg and Horwitz (1986) revealed that induced anxiety can causespeakers to respond more factually and with less interpretation.

### **2.2.2.4. Personal Effects of FL Anxiety**

These effects directly affect an individual psychologically and physically. MacIntyre (1999: 39) suggested that the personal effects of anxiety on a person may be the severe anxiety reaction for an individual language learner and for some students language learning is like a "traumatic experience". To give some example, "they experience apprehension, worry, even dread. They have difficulty concentrating, become forgetful, sweat, and have palpitations" (Horwitz et al., 1986: 126). By comparing 97 anxious and nonanxious college students majoring French, MacIntyre and Gardner (1994), proclaimed that anxious students found it more

difficult to express their own views and tended to underestimate their own abilities. This statement of a student “I’d rather be in a prison camp than speak a foreign language” shows how severe effects language anxiety may cause (Price, 1991: 104).

### **2.2.3. FL Anxiety and Learner Variables: Gender and Academic Status**

As a psychological phenomenon, language anxiety has a wide range of variables influencing it. Due to the fact that learners of a language are personally affected by it, the first variables that come to mind are learner variables. Concerning this issue, Young (1991: 426) mentions;

The problem with much of the research was that the relationship between anxiety and language learning/performance could not be viewed without taking into account an assortment of variables, such as language setting, anxiety definitions, anxiety measures, age of subjects, language skill, and research design.

First and foremost of them is gender variable. One who wants to measure the level of anxiety accurately and precisely must take into account the gender variable. Due to fact that male and female students are physically different and think psychologically different from each other, the effects of anxiety on them differ greatly. Further, they adopt different learning strategies in the process of language learning. To give some example, Bacon and Finneman asserted that men adopted more local strategies while women preferred more global ones when dealing with authentic input (1990). Related to this, by using two radio broadcasts in Spanish, Bacon (1992) tried to obtain students’ comprehension strategies, level of comprehension, confidence, and affective response to the passages. She found significant differences between the responses of men and women in their perceived learning and comprehension strategies. Moreover, female students are more interested in foreign language than male students (Clark and Trafford, 1996). Furthermore, Abu-Rabia tested some variables including teachers’ attitudes, gender, first language reading comprehension, FL reading comprehension, FL spelling, and FL creative writing and their relationship to FL anxiety among 12-13 years of age English learners. He discovered that “male students showed significantly higher

results on all L1 and L2 tests than female students, except as regards teachers' attitudes, which appeared to yield equal results (2004: 717).

Because of the differences mentioned above, the studies in literature gained different and contradictory results. Some researchers (Chang, 1997; Daly, Kreiser, & Rogharr, 1994; Felson & Trudeau, 1991) discovered that female students had higher levels of anxiety than males in academic situations. In the same way, investigating English writing anxiety among Taiwan students, Cheng (2002) found that female students were significantly more anxious than males. Next, Abu-Rabia (2004) put forward the results of his aforementioned study as female students had higher anxiety scores than male students. After examining FL Japanese language class anxiety regarding gender, nationality, first language, and prior foreign language experience, Machida (2001, cited in Matsuda and Gobel, 2004: 23) revealed significant differences in terms of gender in that female learners were more anxious than male counterparts. On the contrary, Aida (2004) carried out a study with 96 second-year Japanese students and found no significant difference in terms of gender on language anxiety. Onwuegbuzie and his colleagues (1999) also obtained no statistically significant relationship between gender and anxiety. Contradicting with the results of previous gender-related anxiety studies, Meji'as et al. (1991) found higher anxiety among Hispanic males than females. Similarly, Kitano's (2001) study brought out male students perceiving their performance in tasks in spoken Japanese to be less capable than others had higher level of anxiety, whereas there was no such relationship among female students.

Another variable considered necessary is academic status or the length of language learning. Commonly this variable is studied as "proficiency". In this study, we preferred to use the terms first-year for beginning, second-year for intermediate, and third-year for advanced levels as Saito and Samimy (1996) did in their study. The relationship between language anxiety and students' proficiency (instructional) levels is covered in many studies. In their study with Japanese learners at beginning (first year), intermediate (second year), and advanced levels (third and fourth year), Saito and Samimy discovered that language class anxiety was the best predictor of

final grades for both intermediate and advanced level students. Advanced students scored the highest, intermediate students the lowest and beginning students' moderate (1996: 245). In contrast with Saito and Samimy's findings, Gardner et al. explored that the beginner students had the highest French class anxiety level scores, advanced students had the lowest scores, and intermediate students fell in between the other two. In this regard, they interpreted that "...the beginners were considerably more anxious than the advanced students, indicating that anxiety about speaking French decreases as proficiency and training increase" (1977: 251). Even though the difference wasn't significant, Liu (2006) stated that the more proficient in English the students were, the less anxious they were in oral English class. In his 233 postsecondary students of Arabic as a FL, Elkhafaifi (2005) found that there was a small but statistically significant negative correlation between both FL learning anxiety and FL listening anxiety and the academic status. Namely, older students; sophomores, juniors, and seniors experienced lower language anxiety than younger students, freshmen.

In a few words, because of the inconsistency of the results on the variables of the length of language learning and learners' gender as mentioned above led us to investigate these learner variables.

#### **2.2.4. Sources of FL Anxiety**

To cope with language anxiety for improving language learning, we need to search out its possible sources. By stating "once the origins of language anxiety completely understood, we may be in an even better position to explain its effects on language achievement", MacIntyre (1999: 33) emphasized the importance of uncovering its potential seeds.

Empirical research on the origins of language anxiety was relatively limited. However, recently, several researchers have addressed this issue. As one of them, MacIntyre expresses that;

At the earliest stages of language learning, a student will encounter many difficulties in learning, comprehension, grammar, and other

areas. If that student becomes anxious about these experiences, if he/she feels uncomfortable making mistakes, then state anxiety occurs. After experiencing repeated occurrences of state anxiety, the student comes to associate anxiety arousal with the second language. When this happens, the student expects to be anxious in second language contexts; this is the genesis of language anxiety(1999: 30-31).

After a close and comprehensive investigation, Young (1994) categorized the sources of foreign language anxiety into three general groups: (a) sources associated with the learner, (b) sources associated with the teacher, and (c) sources associated with the institutional practices.

Characteristics of learner causing foreign language anxiety are low self-esteem; competitiveness(Bailey, 1983); self-perceived low level of ability; communication apprehension(Bailey, 1983; Horwitz et al., 1986; Price, 1991; Young, 1990); lack of group membership with peers; and beliefs about language learning(Horwitz et al., 1986; Horwitz, 1988; Price, 1991; Young, 1991, 1994).

Bailey (1983) posits that competitiveness can cause anxiety when the students compare themselves to other students, to the teacher's expectations in the hope of gaining the teacher's approval, and to an idealized self-image.

Some manifestations of competitiveness can be listed as follows (ibid.:93-94);

1. Overt self-comparison of the language learner: (a) with classmates, (b) with other language learners not in the classroom, and (c) with personal expectations.
2. Emotive responses to the comparisons: (a) hostile reactions toward other students, and (b) connotative uses of language in the diary,
3. A desire to out-do other language learners: (a) racing through examinations, and (b) students shouting out answers in class.

4. Emphasis on or concern with tests and grades: (a) especially with reference to other students; or (b) with a discussion of how tests interfere with language learning,
5. A desire to gain the teacher's approval: (a) perception of the teacher as a parent figure, and (b) the need to meet or overcome a teacher's expectations,
6. Anxiety experienced during the language lesson,
7. Withdrawal from the language-learning experience; (a) mental or physical, and (b) temporary or permanent.

Figure 3. Competitiveness and the second language learner (ibid.: 97)

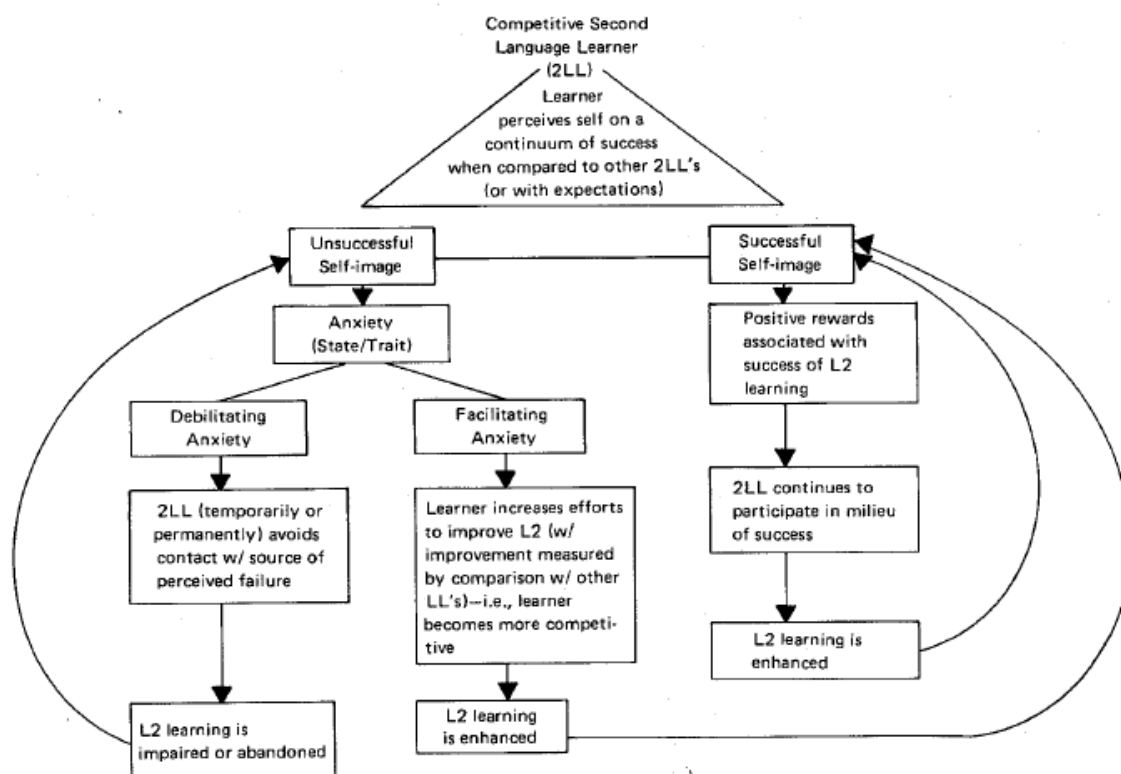

Kitano (2001) supported the claim “low self-esteem as a source of language anxiety” in his research made among college learners of Japanese. He found two main sources of anxiety: fear of negative evaluation and self-perceived speaking ability by expressing that the students compared their speaking ability with other students, with teachers, and with native speakers. Kitano stated that an individual student’s anxiety was higher as he or she perceived his or her ability as lower than that of peers and native speakers.

Krashen (cited in Young) stated that self-esteem was the reason of anxiety for many people. He continued “... people with low self-esteem worry about what their peers think; they are concerned with pleasing others. And that I think has to do a great degree with anxiety” (1991: 427). In this respect, there is an interaction between competitiveness and self-esteem.

Gregersen and Horwitz (2002: 568) investigated the relationship between foreignlanguage anxiety and perfectionism. They explored that anxious students never satisfied with what they accomplished while non-anxious students allowed themselves to celebrate small victories. They concluded that the learners with language anxiety and perfectionists had similar characteristics. These characteristics may cause language learning to be unpleasant and less successful for the learners than for other students who had less anxiety. Even though not only the anxious students but also the non-anxious students were able to recognize their errors during the oral interviews, these two groups had relatively different emotional responses to similar errors.

Learners’ beliefs about language learning may also generate language anxiety. Every student has different notions in his/her mind about language learning. These notions will probably influence the effectiveness in the language learning classrooms. According to Holec (1987, cited in Horwitz), the learners who have different notions about language learning perceive the nature of learning in different ways: "1) learning a language is hard work; 2) for a Frenchman, learning Italian is easier than learning Japanese; 3) spelling is one of the major difficulties when learning French" (1988: 284).

Similarly, Horwitz (1988) listed the findings on the beliefs of the learners of French, German, and Spanish as; (1) language learning has difficulty hierarchy, (2) a maximum of two years is sufficient for learning another language, (3) some people are more able to learn a language than others, (4) it is easier for children than adults to learn a foreign language, (5) learning another language is merely a matter of translating from English or learning grammar rules or new vocabulary words, (6) learning vocabulary words and grammar rules is the most important part of language learning, (7) repetition and practice are essential in the language learning, and (8) speaking with “excellent accent” is important. In this respect, if the learner who believes two years is enough for proficiency in language doesn’t speak a native speaker, this will cause anxiety for him or her. Next, if the learner who cares about learning vocabulary and grammar rules finds nothing about them in the class, s/he will experience language anxiety. Shortly, according to Young (1991: 428), “when beliefs and reality clash, anxiety results”

Radnofsky and Spielmann (2001) found that expectations were crucial in determining how an event or situation could generate tension. For instance, the students who came from traditional backgrounds of grammar-centered expect that all the grammar would be thought in detailed in the textbook. If the curriculum was based on more communicative methods, there would be no separate grammar instruction, but specific points would be explained and discussed. This may create serious cognitive tension in students.

Characteristics of the instructor can also produce language anxiety. Teachers’ attitudes, beliefs and personality have an important role in lessening anxiety. Appleby (1990, cited in Aida, 1994: 164) suggested that students are most irritated by teachers who unempathetic with their needs and who are poor communicators. For Palacios (1998), language anxiety can stem from the following characteristics of the teacher: lack of teacher support, unsympathetic personalities, favoritism, and lack of time for personal attention. Instructor beliefs about language teaching are another source of language anxiety. The teachers who have traditional teaching methods

experience some difficulties behaving as a facilitator, counselor, or role-model in the language teaching process. Young (1991: 428) expresses that;

Instructors who believe their role is to correct students constantly when they make any error, who feel that they cannot have students working in pairs because the class may get out of control, who believe that the teacher should be doing most of the talking and teaching, and who think their role is more like drill sergeant's than a facilitator's may be contributing to learner language anxiety.

In addition, Samimy (1994) suggests that the instructor must change his/her self-image from an authoritarian drill sergeant to a facilitator to promote learners' communicative competence and to foster a sense of community in the classroom. Instructors must modify their perceptions of students' mistakes from "sins" to "natural part of the instruction.

Another factor that may arouse anxiety in the FL classrooms is the interaction between learners and instructor. Here error correction is the case. It is mostly cited as anxiety-provoking while learning a language. The problem is not correcting the students' errors but the manner of error correction – when, how often, and most importantly, how errors are corrected (Young, 1991).

The characteristics of institutional practices including classroom procedures/activities and techniques/methods can contribute to learner language anxiety. Making mistakes in front of peers, testing procedures, and calling on students to speak in front of the class may cause FL anxiety.

In a study conducted by Koch and Terrell (1991), students reported that oral presentations in front of the class/peers are the main factor that producing anxiety. In the same direction, Price (1991) pointed out that speaking in front of their peers was mostly concerned by the students. They were worried about being laughed at, embarrassed, and making a fool of oneself. Their main concern was to communicate effectively and develop a native-like accent. Likewise, testing is another issue as a source of language anxiety. Especially, ambiguous, unfamiliar, and highly evaluative

tests can cause to show up language anxiety. Some students complain that even though they know the subject very well, they can't remember during a test or an oral exercise (Horwitz et al., 1986).

Similarly, Phillips (1992) found a significant negative correlation between FLCAS scores and oral exam grades. Additionally, in the study of Von Wörde (2003), students express that language class moves too quickly to digest the rules and vocabulary. Some others complain that teachers just keep on going and do not reinforce the grammatical items. Choosing students to call on in a row is another anxiety-provoking technique used in the language classrooms.

The following classroom activities compiled by Young (1990) are potential sources of anxiety for the students: (1) spontaneous role play in front of the class; (2) speaking in front of the class; (3) oral presentations or skits in front of the class; (4) presenting a prepared dialogue in front of the class; and (5) writing work on the board.

More specifically, skill-based sources of language anxiety are also investigated by some researchers. As language anxiety in reading and listening classes is our main issue, I want to mention some possible sources of reading and listening anxieties.

On the sources of anxiety in reading classes, Kuru-Gönen (2005) conducted a study with the participations of 50 first-year students majoring at ELT Department of Anadolu University. After analyzed the learner diaries and guided interviews, she grouped the sources under three main categories: personal factors, reading text, and reading course. Personal factors include these sub-categories: inappropriate strategy use (29%), fear of comprehension (26%), lack of motivation (19%), lack of self-confidence (11%), negative background experiences (8%), and high expectations (7%). Sub-categories of reading text are topics (33%), unknown vocabulary (20%), complex linguistic structures (19%), unknown cultural content (17%), and format of the text (11%). Reading course include course book (27%), classroom environment (23%), compulsory reading (22%), teacher (15%), and evaluation (13%).

Recently, Şahin (2011) carried out a study with 6<sup>th</sup>, 7<sup>th</sup>, and 8<sup>th</sup> grade learners of English as a foreign language in Yazılıhüyük Gazi Primary School in Nevşehir, Turkey. A total of 130 learners participated in the study. By replicating the findings of Kuru-Gönen' study, she found 5 main factors provoking foreign language reading anxiety. They include reading task (86.15%), attitude of the teacher (84.62%), nature of the text (83.62%), personal factors (82.89%), and classroom environment (80.31%).

In another study conducted by Köroğlu (2010), the participants were 113 Turkish preparatory and first year ELT students at Ataturk University of Erzurum. The results revealed that new words, lacking background information of the text, and open-ended questions were identified as the main sources of foreign language reading anxiety.

As for the sources of language anxiety in listening classes (listening anxiety), after comprehensive investigation, Vogely (1998) grouped the factors under four main categories: input, process, instructional factors, and personal factors. The factors that cause anxiety in the input stage of listening are nature of the speech (28%), level of difficulty (11%), lack of clarity (5%), lack of visual support (4%), and repetition of input (3%). In the stage of process of listening, inappropriate strategies (24%), lack of time to process (3%), can't study for listening comprehension (2%), and can't check answers (1%) produce l-anxiety. Instructional factors include lack of listening comprehension practice (3%), the testing thing (2%), and uncomfortable environment (1%). Personal factors involve fear of failure (10%), nerves (2%), and instructor's personality (1%). As it can be easily understood from these results, listening comprehension anxiety mostly associated with the characteristics of foreign language input followed by processing-related aspects of foreign language.

On listening anxiety, another study was carried out by Bekleyen (2009) with the participation of 71 first-year students majoring in English language teaching at Dicle University in Diyarbakır. Having analyzed the results of a semi-structured interviews, she explored inadequacy of previous education (50%), failure to recognize the spoken form of a known word (41%), failure to identify segments of sentences (35%), failure to recognize weak forms of words (28%), poor quality of the

listening materials (20%), failure to understand different accents and dialects (15%), lack of topical knowledge (11%), and lack of vocabulary or grammatical knowledge (6%) as the possible causes of foreign language listening anxiety.

In his review of the second language listening comprehension research, Rubin (1994) searched out five factors that researchers believed affect listening comprehension: (1) text characteristics (listening passage/text or visual support); (2) interlocutor characteristics (speaker's personal characteristics); (3) task characteristics (purpose for listening and responses); (4) listener characteristics (listener's personal characteristics); and (5) process characteristics (listener's cognitive activities and interaction between speaker and listener).

Lastly, Kılıç (2007) investigated the sources and relations of foreign language listening anxiety as a case study at Gaziantep University with 157 Turkish EFL students. He listed 14 possible sources listening anxiety and asked the students to choose the sources that affected their levels of listening anxiety. The students ticked the sources affecting their anxiety levels as “yes” or “no”. The possible sources of anxiety and their percentages are as follows: *number of the unknown words* (56.53%), sound quality (disturbances, low volume etc.) (50%), number of the speakers (7.35%), *pace of the listening* (88.87%), background noise (13%), length of the listening text (35.23%), unfamiliarity of the topic (15.36%), *intonation, stress, and pronunciation* (64%), concentration problem (49.13%), lack of visual help (e.g. pictures, videos, maps) (38.16), inconfidence in listening ability (34.03%), lack of skills in listening comprehension (26.13%), psychological state (29%), and difficulty of the multiple-choice questions (11%). Among 14 possible sources of listening anxiety, number of unknown words, pace of listening, and intonation, stress and pronunciation are the most influential sources of listening anxiety. The results replicated the findings of Kim (2000) in her dissertation: *Pace of Listening; Intonation, Stress, and Pronunciation; and Number of Unknown Vocabulary Items*.

In this study, however, the researcher has planned to identify the sources of language anxiety in reading and listening classes specifically. Therefore, the pre-identified sources of reading and listening anxiety are grounded on both Young's

(1994) and Vogely's (1998) study. He has selected the following possible sources of anxiety as the baseline for this study.

Possible sources of reading and listening anxiety;

1. ***Factors associated with the learner:*** (a) Linguistic incapability; (b) Cognitive inability; (c) Lack of motivation/confidence/self-esteem; (d) Cultural beliefs/attitudes; (e) Fear of failure/making mistake; (f) Competitiveness; (g) High expectations/perfectionism; (h) Negative classroom experiences.
2. ***Factors associated with the instructor:*** (a) Interaction with the learners/attitudes; (b) Error correction/giving feedback; (c) Classroom management; (d) High expectations/perfectionism; (e) Unsympathetic personality.
3. ***Factors associated with the reading text:*** (a) Unknown grammatical structures /words; (b) Format of the text (clarity, length, visual aids); (c) Topic of the text (inauthenticity, unfamiliarity, lack of background information).
4. ***Factors associated with the reading process:*** (a) Methodology (methods, strategies, and program); (b) Uncomfortable/insecure classroom environment; (c) Classroom activities (public speaking, presentations); (d) Evaluation (test types, exams).
5. ***Factors associated with the interlocutor/speaker:*** (a) Speech (pronunciation, intonation); (b) Gender of the speaker; (c) Number of speakers; (d) Nationality of the speaker.

#### **2.2.5. Ways of Reducing FL Anxiety**

While the early studies were based on the identification the negative effects and possible sources of anxiety, in recent years, language anxiety literature has mostly focused on the ways and strategies to reduce language anxiety.

As pedagogically, Horwitz et al. (1986) suggest that instructors have two options to cope with anxious students: (a) they can teach them how to deal with the anxiety-producing situations; or (b) they can create a more secure learning setting. The very first step of this is to raise the teachers' awareness about the anxiety. They also acknowledge the existence of anxiety before helping the students. Altering the context of foreign language learning is of crucial. The teachers also should be sensitive to correct errors. The techniques that they adopt should be based on instructional philosophy. Similarly, Aida put emphasis on the role of teacher in lessening classroom anxiety by creating a friendly, secure, and supportive atmosphere. The author also expressed that "students will appreciate and learn more from teachers who are able to identify students experiencing foreign language anxiety and take proper measures to help them to overcome that anxiety" (1994: 164). Saito and Samimy (1996) also emphasized "psychologically secure environment" for students taking risks in the second language context.

Brophy (1999, cited in Gregersen and Horwitz, 2002: 569) made the following suggestions for the teachers;

- (a) building a friendly, supportive learning environment,
- (b) establishing the expectation that mistakes are a normal part of the learning process,
- (c) presenting themselves as helpful instructors concerned primarily with promoting student learning, rather than as authority figures concerned primarily with evaluating student performance,
- (d) articulating expectations that stress learning and improvement over perfect performance of assignments,
- (e) explaining how perfectionism is counterproductive,
- (f) reassuring perfectionist students that they will get the help they need to achieve success,
- (g) following through with help, and communicating teacher approval of students' progress and accomplishments.

McCoy (1979) suggested some specific techniques to allay students' anxiety including relaxation techniques, advice on effective language learning strategies, behavioral contracting, and journal keeping. Focusing on "how to teach" instead of "what to teach", Ellis and Sinclair (1989) put forward teachers' training to be able to teach in better ways. Campbell and Ortiz (1991) recommended that students should share their feelings and experience with their teachers and peers and keep a journal about language anxiety.

Phillips put forward some implications about speaking performance and oral testing. (a) By creating a less stressful classroom environment, instructors should allow students focus on communication rather than worry and fear of evaluation. (b) Teachers should discuss the phenomenon of language anxiety with students to make them feel they are not the only ones who suffer anxiety. (c) Teachers should provide them with realistic expectations to assure that learning a language is a lengthy process and that errors are a natural part of that process (1992: 20). (d) Teaching affective strategies explicitly may also support their dealing with anxiety in language learning and testing situations.

Related to reading anxiety, to Saito et al. (1999: 217), teachers may be able to help their students by "(a) acknowledging the unique characteristics and features of their target language; (b) carefully selecting authentic materials to demonstrate how students can use the vocabulary and structures they have been studying; (c) bringing students into discussions of the language learning (and reading) process, ensuring that teaching goals are appropriate and attainable, and helping students recognize that they can be successful; (d) pacing the course so that students are challenged but not faced with a cognitive overload; (e) teaching successful learning and reading strategies; and (f) devoting more class time to predicating activities and assessment of reading objectives."

Sellers (2000) suggested the following instructional practices. Teachers should make use of authentic texts as comprehensible input even for beginners. Next, these authentic materials should be used to prevent anxiety and inhibition of second language performance.

On reducing listening anxiety, Elkhafaifi (2005) also made some recommendations. To him, teachers should provide comprehensible input and create more opportunities for listening practice, as well. Specific listening strategies may also be taught to help students to store and recall what they hear. In addition to providing comprehensible input, instructors must teach learners “how to teach” (Mendelsohn, 1995, cited in Elkhafaifi, 2005: 215). In terms of unrealistic expectations, teachers should help students overcome them. They should pay extra attention on selection authentic materials to provide authenticity in listening classes. These materials should also have an appropriate level of difficulty. Instructors should provide such a secure classroom atmosphere that student should be able to share their common feelings on language anxiety.

Vogely (1998) suggested numerous pedagogical implications to alleviate listening anxiety in her study about sources and solutions of listening comprehension anxiety. The students’ suggestions for lessening listening comprehension anxiety and their percentages are as follows:

*1. Suggestion based on input (31%):* (a) making input comprehensible (the input should be based on familiar, meaningful topics and vocabulary. For many others, it should be informal and ungraded); (b) using variety of input (games and fun activities should be used in listening activities. Moreover, apart from these, small group activities, practice with listening from a tape or the radio, and hear the students’ cassette tapes in class are suggested by the students); (c) structure tasks (the teacher should let them know what they are doing. Clear instructions, advanced organizers and structured tasks may lessen their anxiety).

*2. Suggestions based on process (4%):* For Vogely, the reason why the percentage of this is low may be their not being aware of the strategies while listening. (a) focusing on strategies needed (teacher should help them to be able aware of their skills and use effective strategies, accordingly); (b) notetaking/use of English (for students, it would alleviate their anxiety if the teacher let them take notes during a listening comprehension task and if they evaluated on the basis of their native language).

3. *Suggestions based on instructional factors (60%):* (a) increasing class time for listening comprehension (there should be enough time for listening comprehension activities); (b) combining listening comprehension with other skills (it would be better for students to combine listening activities with reading skill. That is to say, the students want to see a written material while they are listening it);(c) providing regular feedback (immediate and positive feedback are helpful for decreasing anxiety); (d) creating out-of class opportunities (informal and social interaction with the native speakers is a good way of experimenting their language out of the classroom).

4. *Suggestions based on personal factors (5%):*(a) experiencing small successes (letting them experience small success increase their self-confidence);(b) meditation /breathing, etc. (using anxiety-reducing techniques can decrease language anxiety to some extend).

There are some strategy-based recommendations in the literature like cognitive strategies, metacognitive strategies, affective strategies, social strategies, and behavioral strategies (Oxford, 1990; Hembree, 1988). Cognitive strategies which are related to transformation and processing of the target language by repeating, analyzing, practicing, and summarizing are most popular strategies in language learning. Cognitive domain involves coding of linguistic stimuli, knowledge, and the development of intellectual skills. For instance, generalizing, making comparisons between languages, making associations between words, practicing, analyzing and reasoning (Oxford, 1989). Metacognitive strategies are based on the knowledge and self-awareness of a learner in his/her own language process. That is to say, learning to learn is the case. Metacognitive awareness includes language awareness, cognitive awareness, social awareness, and cultural awareness (Ellis, 1999). The development of metacognitive awareness is considered to be the key to successful learning. It helps students to understand the significance what they are doing. For Ellis and Sinclair, (1989), learners mayunable to transfer strategies to other tasks without the combination of metacognitive and cognitive strategy development. Metacognitive strategies contain being aware of and thinking on the learning process, planning,

monitoring, and self-evaluating, self-management, and setting goals and objectives (Oxford, 1989). Affective strategies involve our affective behaviors such as feelings, value system, appreciation, willingness, enthusiasm, motivations (intrinsic and extrinsic), emotions, and attitudes. They help create a positive environment for language learning. Language learners should be able control their attitudes and emotions and generate their own motivation about language learning. Social strategies have great importance in language learning as knowing a language means to be able communicate with people. These strategies include asking questions, cooperating with others, counting on friends for help, participating in group conversations, and empathizing with others. Especially, cooperation is very important in terms of eliminating competition. Also, it provides higher self-esteem, higher self-confidence, and rapid achievement. Behavioral strategies are based on training people in study skills and preparation for effective performance in academic skills. These include improving language learning strategies and studying harder.

Kondo and Ying-Ling (2004) developed a typology of strategies adopted by the students to cope with anxiety. They identified 70 basic tactics to reduce language anxiety. These tactics were grouped under five strategy types as preparation (e.g. studying hard, trying to obtain good summaries of lecture notes), relaxation (e.g. taking a deep breath, trying to calm down), positive thinking (e.g. imagining oneself giving a great performance, trying to enjoy the tension), peer seeking (e.g. looking for others who are having difficulty controlling their anxiety, asking other students if they understand the class), and resignation (e.g. giving up, sleeping in class). They had hypothesized that anxious students made use of cognitive, affective, and behavioral strategies, as well as resignation in the language classroom before conducting the study. Cognitive strategies subsume positive thinking and peer seeking which are efforts to prevent or modify problematic notions about language learning. Relaxation can be subsumed into affective strategies as it is related to emotional arousal. Preparation is accepted as a behavioral strategy in that it requires studying for language skills.

As for this study, the researcher has tried to explore the participants' ways of reducing language anxiety in reading and listening classes on the basis of the following pre-identified ways. These factors have been determined after reviewing of the literature. The factors are;

1. ***Strategies associated with the learner*** (based on Kondo and Ying-Ling's (2004) study): (a) Cognitive strategies (positive thinking, peer-seeking); (b) Affective strategies (deep breathing, motivate yourself, try to calm down); (c) Behavioral strategies (improve language learning strategies, preparation, studying).
2. ***Factors associated with the instructor:*** (a) Creating friendly/secure classroom environment; (b) Raise awareness (talking about anxiety); (c) Giving positive feedback; (d) Teaching language learning strategies; (e) Outline course objectives regularly.
3. ***Factor associated with the reading/listening process:*** (a) Pedagogical practices (pair and small group work); (b) Evaluation (testing); (c) Classroom environment; (d) Choosing the text (to be involved in decision making process).

#### **2.2.6. FL Anxiety and Language Skills**

This section focuses on the effects of anxiety on both productive skills; speaking and writing and receptive skills; reading and listening. Instead of approaching it as general foreign language learning anxiety, focusing on anxiety skill-specific let us examine more thoroughly this phenomenon. As each language skill is distinct and has its own unique framework, operating principles, goals, and in turn drawbacks, it is of crucial to focus on skill-specific. In a similar way, Cheng, Horwitz and Schallert (1999: 439) expressed that

...this trend is encouraging because it foreshadows the development of more sensitive and appropriate measurement instruments that can diagnose learners' anxiety problems more accurately, a prerequisite to more effective interventions.

Recently, the researchers have concentrated on the relationship between language anxiety and language skills; speaking, reading, listening, and writing. However, these efforts as Horwitz et al. (1986: 125) stated “have met with mixed results”, as it is a self-perception issue.

#### **2.2.6.1. FL Anxiety and Productive Skills**

Both speaking and writing are known as productive skills. First of all, one listens and understands his/her partner, and then s/he speaks accordingly. However, the former is differs from the latter as it is also an interactive skill (Carter and Nunan, 2002) and also a reciprocal skill. That is, when the listener has difficulty in understanding what the speaker says, they cannot negotiate meaning (Bozatli, 2003).

The researchers in the context of language anxiety (Horwitz et al., 1986; Young, 1986, 1990; Price, 1991) are of the same opinion that anxiety can inhibit language learning and production. Foreign language anxiety impedes speaking and writing in terms of production.

##### **2.2.6.1.1. FL Anxiety in Speaking Skill**

Because, knowing a language is commonly accepted as to speak it, speaking skill receives more attention than other skills. Relatedly, Arnold (2000: 3) asserts that “the speaking skill is so central to our thinking about language learning that when we refer to *speaking* a language we often mean *knowing* a language.” Most teaching principles focus on production; not on the reception. In that circumstance, studies on language anxiety suggest that as an oral skill, speaking is problematic and extremely anxiety-provoking, and therefore the most challenging aspect in foreign/second language learning (Horwitz et al., 1986; Phillips, 1990; Price, 1991; MacIntyre and Gardner, 1991). A possible reason of it may be speaking requires spontaneous process of input and output.

On this issue, Horwitz and associates discovered together with listening, speaking was the skill that anxiety centered on by stating “difficulty in speaking in class is probably the most frequently cited concern of the anxious foreign language students seeking help at the Learning Skills Center” (1986: 126). It was not problem

to respond to a drill or deliver prepared speeches for students, but they “freezed” in a role-play situation. They supported their claim with the items of Foreign Language Classroom Anxiety Scale (FLCAS). That is, 49 % of participants agreed with the item 9: “I start to panic when I have to speak without preparation in language class”, 33% of them chose item 27: “I get nervous and confused when I am speaking in my language class”, 28% accepted item 24: “I feel very self-conscious about speaking the foreign language in front of other students”, and 47% didn’t agree with item 18: “feel confident when I speak in foreign language class” (1986: 129). For Young (1990: 540), the possible reason behind the fear of speaking in a foreign language is “it may be related to a variety of complex psychological constructs such as communication apprehension, self-esteem, and social anxiety.

Anxiety in speaking skill also influenced on interpretive function. Steinberg and Horwitz (1986) searched the effect of induced anxiety on the denotative and interpretive content of second language speech. Regarding the quality of use of language, the individuals with a higher level of anxiety showed a tendency to be less subjective and more objective in their oral responses than others with a lower level of anxiety. In line with this, Young (1986) claimed that the bigger the group in which the learners spoke the language, the higher the level of anxiety they experienced. In other words, anxious students tried not to choose difficult and personal messages in the target language.

By stating speaking anxiety as “a significant predictor of achievement”, Woodrow (2006) conducted a study in an ESL context to investigate the relationship between learners’ oral performances and their speaking anxiety by grading according to fluency, language use and pronunciation and revealed that the learners who had a higher level of second language speaking anxiety performed worse in the oral exam.

There is a significant correlation between self-perception and communication apprehension (speaking anxiety). The students with low self-esteem perceive themselves less capable of communicating than their peers. This is one of the possible sources of anxiety in speaking. From this point of view, Daly (1991) asserted that the learners with higher communication apprehension had lower self-esteem. Similarly, having interviewed with 15 highly anxious university students,

Price (1991) found that to speak the target language in front of their peers as well as their fears of being laughed at by the others” and “making a fool of themselves in public” was the greatest source of anxiety. She concluded that the majority of her subjects believed that their language skills were weaker than those of the other students. Lastly, from this perspective, Foss and Reitzel (1991: 133) stated that “some second language learners may choose not to communicate in a situation”. The reason of this is that “they judge their capabilities in the new language to be so poor that not communicating is perceived as more rewarding than doing so”. In addition, having found self-confidence as a key variable and influenced L2 proficiency both directly and indirectly, Matsuda and Gobel concluded that “reducing anxiety and enhancing self-confidence by encouraging students’ involvement in classroom activities and creating a comfortable atmosphere was of crucial” (2004: 32)

In terms of effects of anxiety in speaking skill, according to Phillips (1992: 18);

There was a significant inverse relationship between the students’ expression of language anxiety and their ability to perform on the oral exam. The negative correlations confirm that students with higher language anxiety tended to say less, to produce shorter communication units, and to use fewer dependent clauses and target structures than low anxiety students.

Similarly, other effects of anxiety in speaking includes “distortion of sounds, inability to reproduce the intonation and rhythm of the language,” as well as “freezing up when called on to perform, and forgetting words or phrases just learned or simply refusing to speak remaining silent” (Young, 1991: 431).

As for possible sources anxiety in speaking skill, after analyzed of the learners’ comments in the diaries and interviews, Aydın (1999) put forward three main sources of foreign language anxiety in speaking and writing classes; personal reasons (negative self-assessment of ability, self-comparison to other students, high personal expectations, and irrational beliefs about language learning), teachers’ manner (towards students’ error, towards students), and teaching procedures

(speaking in front of the classroom, making oral presentations, studying individually, writing in the paragraph form). In line with Aydın's study, Subaşı (2010) investigated the main sources of the students' anxiety in oral practice. She discovered that personal reasons, teachers' manners, teaching procedures, and previous experience were main sources of anxiety in speaking in the target language. Lastly, Balemir (2009) listed them as oral tests, self-assessment of speaking abilities, self-comparison to others, and fear of negative evaluation.

#### **2.2.6.1.2. FL Anxiety in Writing Skill**

Like speaking, writing is a productive skill, that is, one needs to produce something in written. Of the four skills, writing seems to be the least anxiety provoking situation (Leki, 1999). Concerning this, Abu Shawish (2009: 1) states that "writing is not an easy task, as some people may think; it is rather sophisticated skill, if compared with other language skills, which may need less effort". Writing skill is the assortment of various mental activities. From this point of view, Abu Shawish and Atea (2010: 1) posit that;

It involves different mental activities before being performed in their final written form. It needs that the writer should think, compose and create ideas, check their relatedness to each other and to the main idea of the topic, memorize and recall lexical items thought to be more relevant than others, sift and discard irrelevant ideas, organize these ideas according to their importance in a way to develop the main idea i.e. theme of the topic.

Daud and Kassim carried out a study to examine the relationship between anxiety and writing performance. They found that low performing students were more anxious than high performing students. The reason behind was deficiency in certain dimensions of writing skills, especially vocabulary and language use. They stressed the need to expose students to more English and adopt task-based or problem-based approaches instead of the lecture-based approach. Lastly, the target language should be used in authentic tasks or situations by students.

Self-esteem is an overstressed issue in the literature of anxiety in writing skill. In this regard, having posited that;

...there is a need to investigate the variable ‘writing apprehension’ in an Arabic speaking context given that studies investigating writing apprehension and self-esteem in their relationships to the writing quality and quantity of university students in such context, to the best knowledge of this writer, do not exist (2005: 12-13).

Hassan explored the effects of writing apprehension and self-esteem on the writing quality and quantity of 182 EFL students majoring in the English Department at Mansoura University by assessing their compositions. He concluded that there was significant relationship between writing apprehension and self-esteem. That is to say, “students with high apprehension about writing may, to some degree, also suffer from lower self-esteem than their counterparts with low apprehension” (2001: 19). Also, “low apprehensive students wrote better quality compositions than their high apprehensive counterparts” (2001: 21). On the other hand, self-esteem and writing apprehension didn’t affect the writing quantity task. After these findings, he recommended that “...reducing student writing anxiety by changing the context of foreign language learning is the most important and considerably the most challenging task for teachers to try to achieve” (2001: 27). He also emphasized the teacher correction and evaluation. In parallel with Daud and Kassim (2005), students should be involved in more communicative writing tasks.

Furthermore, offering second language classroom anxiety and second language writing anxiety as two related yet relatively distinguishable anxiety constructs, Cheng et al. (1999) suggested that low self-confidence seems to be an important component of writing and speaking anxieties.

As for the possible reasons of anxiety in writing skill, for Leki (1999) practicing grammar in writing courses creates anxiety. In other words, instructors shouldn’t evaluate the writing tasks in terms of grammatical mistakes or language use. Poor writing skills and fear of evaluation by others are other possible sources of anxiety. According to Kim (2002) lack of vocabulary and lack of confidence in

meeting the instructor's expectations may be the case. Cheng expressed that "perceptions of their competence rather than their actual competence play a much more important role in their experience of L2 writing anxiety" (2002: 652). Abu Shawish and Ateia (2010: 2-3), who reviewed the literature and listed the causes of high levels of writing apprehension:

- a) Focus and overemphasis on form like grammar, punctuation, and generally perceptive writing,
- b) Writing tutors' adoption of product approach,
- c) Instructors' not teaching the teachable aspect of writing,
- d) Students' writing being evaluated by teachers or peers,
- e) Students' deficits in skills and teacher negative responses to early writing attempts,
- f) Lack of revision and revision skills,

#### **2.2.6.2. FL Anxiety and Receptive Skills**

Reading and listening skills are receptive skills. They are called as receptive skills as both of them are based upon the reception, comprehension, understanding, and decoding what is being said or read. The receptive skills enable the productive skills (Sarıçoban, 1999). That is to say, these skills are essential skills and come first in language learning since understanding of words and language is of importance in order to communicate successfully. These two skills are required for comprehensible input especially in EFL contexts like Turkey. Students should have the basic language comprehension skills to be able to learn a new language. In terms of acquiring a first or second language and learning a foreign language, the required and needed comprehensible input is provided by reading a text and listening to a target message.

Even though the aforementioned significance of receptive language skills in acquiring or learning a language is well-known, the EFL course books in primary and high schools often are based on grammar and vocabulary. Moreover, the texts used in the books frequently applied for the presentation of a new language use, that is, again they include grammatical structures. More interestingly, in ELT departments in Turkey, these skills are mostly limited to the first-year of university.

In view of these, reading and listening language skills are open for the danger of language anxiety.

### 2.2.6.2.1. FL Anxiety and Reading Skill

As a receptive skill, reading is defined by Grabe and Stoller (2002: 9) as “... the ability to draw meaning from the printed page and interpret this information appropriately.” For Urquhart and Weir (1988:22) define it as “reading is the process of receiving and interpreting information encoded in language form via the medium of print”. Lastly, Anderson (1999: 1) states “reading is an active, fluent process which involves the reader and the reading materials in building meaning. Meaning does not reside on the printed page, nor is it only in the reader.”

As understood from the definitions above, reading comprehension involves complex thinking, various mental operations, and ability to interpret and analyze the text, making sense of words, and negotiating meaning.

Grabe and Stoller show the complicated reading processes as below;

Table 1. Reading processes

Lower-level processes	Higher-level processes
* Lexical access	* Text model of comprehension
* Syntactic parsing	* Situation model of reader interpretation
* Semantic proposition formation	* Background knowledge use and inferencing
* Working memory activation	* Executive control process

They continue;

The lower-level processes represent the more automatic linguistic processes and are typically viewed as more skills orientated.

The higher- level processes generally represent comprehension

processes that make much more use of readers' background knowledge and inferencing skills (2002: 20).

According to the Input Hypothesis along with listening, reading is an essential mean of comprehensible input. In comparison with listening, students have more opportunities for reading skill. On this issue, Horwitz (2008: 115) states that "many second language learners have limited opportunities for authentic listening experiences, but reading can give learners easier access to many types of language they would not otherwise encounter." Reading has many benefits for learners in terms of cognitive, social, academic, etc. These include;

- (a) Reading provides to gain prestige in society; it makes you knowledgeable and well-versed in newly developments,
- (b) Reading is a key for academic success; it improves your vocabulary, grammar, and other language skills,
- (c) Reading is a primary leisure time activity; it helps you relax and recreation and reduces boredom,
- (d) Reading leads to greater cognitive development; one can think creatively and smartly,
- (e) Reading contributes to cultural development; it gives you an insight into the diversity of ethnicity of people, their customs, their lifestyles etc.,
- (f) Reading contributes to personal development; it builds one's self-esteem.

Because of such importance and complex features mentioned above, it makes reading unavoidable to be damaged due to language anxiety. Therefore, in contrast to the hypothesis that only production skills are badly affected by language anxiety, reading as a receptive skill is also harmed by language anxiety. Then, the question is "is reading comprehension harmed by general foreign language anxiety or a kind of anxiety unique to this skill?" Regarding this, Wu (2011) conducted a study in Taiwanese English as a foreign language reading classes. She investigated the relationship between language anxiety and reading anxiety, and if students' reading comprehension performance differs across different levels of language anxiety and reading anxiety. The effects of gender and the length of language learning on

students' language anxiety and reading anxiety were also explored. The results of 91 university students showed that reading anxiety was related to language anxiety, but they were different phenomena in foreign language learning. She didn't find a significant correlation between reading comprehension and levels of language and reading anxiety of the students. Moreover, there was no difference in terms of gender in language anxiety and reading anxiety. Language anxiety of students decreased as their length of learning increase; but there was no difference in reading anxiety. She concluded that students who had language anxiety tended to have reading anxiety. To improve students' reading comprehension performance, creating a low-anxiety classroom atmosphere is essential.

In the context of language anxiety, many studies have been conducted for years. On one hand, most of the research has centered on oral performance anxiety, anxiety in reading skill has drawn little attention as it was thought not to cause any anxiety. On the other hand, reading anxiety has grabbed the attention especially in Turkish EFL context recently. To give some examples, Belgin Aydın is one of the pioneers of language anxiety in Turkey. She conducted some studies on anxiety and several other studies were conducted on this issue under her supervision. Kuru-Gönen (2005) carried out a study on the sources of foreign language reading anxiety. She aimed at explore the sources of foreign language anxiety from 50 EFL students' perspectives. After seven-week kept diaries and interviews with 25 students, she identified three main sources of FL reading anxiety in a Turkish EFL context. They were personal factors, the reading text, and the reading course. Additionally, she suggested that FL reading anxiety was a distinct phenomenon.

Another study conducted recently by Aydın and Kuru-Gönen (2012) was on modification of a reading program based on the sources of FL reading anxiety identified in Kuru-Gönen's (2005: 24) study. They modified the second year reading program by regarding the problems students experience while reading in the first year of the university. Based upon the sources of the anxieties students experience in the first year, they included the following components in the second year reading program;

- a) Not following a specific course book (involving students in the decision making process),
- b) Keeping a reading journal,
- c) Free reading (students are able to choose their texts),
- d) Extensive reading.

They concluded that obtaining students' opinion, giving them responsibility, and involving them in decision making process enhance motivation, confidence, and analytical skills while reading in a foreign language.

When the word "reading anxiety" is pronounced, Saito, Garza, and Horwitz come to mind as a first. They are the cornerstone of the phenomenon: reading anxiety. They constructed the "Foreign Language Anxiety Scale (FLRAS) in 1999 to determine if reading in the target language is anxiety-provoking for some language learners. They conducted their study by adopting, along with FLCAS, this newly developed measure of specific foreign language reading anxiety in 30 intact first-semester classes of Spanish, Russian, and Japanese. They found negative relationships between both the FLCAS and FLRAS and final grades. However, the relationship between reading anxiety and achievement was smaller than for the FLCAS. That is, the participants tended to show lower levels of reading anxiety than general foreign language classroom anxiety. Also, unlike general foreign language anxiety, participants had different levels of reading anxiety based on their target language and it seems to be related to the specific writing. In that, Japanese students had the highest levels of reading anxiety, followed by French students and Spanish students. This finding was surprising for the writers as they hypothesized that Russian students had the highest levels of reading anxiety because of the use of the Cyrillic alphabet. As a result, they concluded that foreign language reading anxiety is distinguishable from the more general foreign language classroom anxiety.

Anxiety in reading skill harms the quality of reading comprehension. Anxiety impedes readers' ability to concentrate on the reading task. Sellers (2000) investigated the relationship between language anxiety and reading in Spanish. She explored the effect of language anxiety on the reading comprehension and recall of

89 university-level language students. The effect of language anxiety on the reading process and the number of off-task thoughts of each participant while reading were also examined. She suggested that learners with higher levels of L2 anxiety also tended to have higher levels of L2 reading anxiety and vice versa. The results showed that the students with higher levels of anxiety tended to recall less passage content than the students with lower levels of anxiety. The results of Cognitive Interference Questionnaire indicated that highly anxious students tended to experience more off-task (interfering thoughts) than the less anxious students.

The relationship between reading anxiety and strategies used in reading has attracted much attention in this context. Many researchers have covered the effects of reading anxiety on reading strategy use. For example, recently, Lien (2011) investigated the relationship between 108 EFL learners' reading strategies use and reading anxiety and gender. The results revealed a negative correlation between reading anxiety and reading strategies. Moreover, general reading strategies like guessing was used by the learners with low anxiety levels, whereas highly anxious learners employed translation as basic support mechanisms to help themselves to comprehend the text. In addition, female students were slightly more anxious than male students in reading. Similarly, Song (2010) explored the effects of foreign language reading anxiety on 45 Korean ESL learners' reading strategy use and reading comprehension. The results of data collected from a background questionnaire, FLRAS, and the Cognitive Interference Questionnaire indicated that there was a fair amount of FL reading anxiety among Korean ESL learners. The study revealed that anxiety can affect learners' reading process with regards to their strategy use and cognitive interference. The students with higher levels of anxiety and with off-task thoughts were in tendency to use more local strategies like using context clues to guess unknown portions, using a dictionary, paying attention to particular features of the text, rephrasing sentences, etc. while less anxious students, contradicting to Sellers study (2000), used more global strategies like connecting ideas, rereading a portion of the text, making or confirming guesses or inferences, identifying main ideas, reading ahead, and summarizing paragraphs. As a last, the learners with higher levels of anxiety showed lower reading comprehension.

#### 2.2.6.2.2. FL Anxiety and Listening Skill

Receiving language through the ears is known as listening. However, listening and hearing are not the same. While the former is an active process, the latter is a passive process. Moreover, *hearing* is the first stage of what we called “active listening” and includes identifying the sounds of speech. The second and third stages of the process of active listening are *understanding* and *judging*, respectively. It is also an interactive skill rather than a passive skill. Even if you listen a radio programme, you interact with the text behind it.

According to Input Hypothesis, listening comprehension has a major role to acquire a second language with the help of comprehensible listening input (Krashen, 1985). This appropriate listening input is also important for speaking skill. Relatedly, the ancient Greek philosopher Diogenes puts forward that “we have two ears and only one tongue in order that we may hear more speak less.” Listening is considered to be the one of the most important part of the oral communication. Furthermore, it is the first language skill followed by speaking, reading, and writing to be learnt in the first/native language. For second language, listening is a matter of debate. That is, some suggest that it be the first skill to be learnt in second language learning while some others disagree with them. What is an indisputable fact about listening is that it is an important factor to be able to communicate in a language. Leonard Bloomfield (1942, cited in Poelmans, 2003: 3) expressed that ‘one learns to understand and speak a language primarily by hearing and imitating native speakers’. To Sariçoban (1999: 4), the most important features in listening to English as a foreign language include;

- (a) Coping with the sounds,
- (b) Understanding intonation and stress,
- (c) Coping with redundancy and noise,
- (d) Predicting,
- (e) Understanding colloquial vocabulary,
- (f) Fatigue,

- (g) Understanding different accents,
- (h) Using visual and environmental clues.

On the other hand, listening poses a challenge for a wide range of reasons. Some of them are the following (retrieved from <http://coerll.utexas.edu> on June 17, 2012)

- ✓ *Listening involves multiple modes:* It has interpersonal and interpretive modes of communication.
- ✓ *Listening involves all varieties of language:* It presents different kinds of colloquialism.
- ✓ *Listening involves “altered” and “reduced” language forms:* It includes “I wanna, gonna, ya, hafta, etc.”
- ✓ *Listening involves variable rates of delivery:* unlike the reading, you cannot control the speed of the speech.

Of the four skills, in addition to speaking, listening skill is frequently neglected in language classrooms. Some possible reasons of it include; (a) evaluating or testing listening comprehension is a challenging task, (b) lack of technical and educational equipment, and (c) it is thought that students can learn it naturally on their own in the classroom. Hence, there exist some communication problems. On this point, Poelmans (2003) expresses that “the main cause of this communication problem is the disability of listeners to recognize the words in the pace in which they are spoken. In other words, listeners may have enough vocabulary knowledge but they may be unable to use this knowledge under time pressure”. Because of all the aforementioned factors, listening skill is in a very vulnerable position against language anxiety which can interfere with listening comprehension.

The relationship between listening comprehension and language anxiety has attracted a greater level of interest in recent years than it did in the past. Bekleyen (2009) conducted a study on foreign language listening anxiety (FLLA) among language teacher candidates (TCs). To collect data, she used two quantitative measures; FLCAS and FLLAS, a set of open-ended interview questions, and

listening tests. The results revealed a significant positive relationship between the FLCAS and FLLAS. It means students with higher levels of foreign language classroom anxiety tend to have higher levels of foreign language listening anxiety. Next, the teacher candidates had high FLLA levels with the mean 95.30 out of 165. There was a significant negative relationship between students' listening anxiety levels and their listening grades. Highly anxious students tended to get lower final grades in the listening course than their less anxious counterparts. On the other hand, there were no statistical difference between the gender and FLLA even though female students had slightly higher mean scores (94.64) than male students (92.27). Inadequacy of previous education and failure to recognize the spoken form of a known word were the two mostly cited sources of listening anxiety for them. As for the effects of listening anxiety, they mostly showed an avoidance behavior; they avoided the situations requiring listening skill. The other effect appeared as physical symptoms like accelerated heartbeat, perspiration, blushing and stuttering.

In another study, Gönen (2009) investigated the relationship between foreign language listening anxiety and foreign language listening strategies with the participation of 60 students at the intermediate English proficiency level. The first finding showed that 42 out of 60 intermediate level students felt listening anxiety. Another finding revealed a medium level of strategy use. In other words, the participants didn't employ many listening strategies; it was an average level. On the other hand, when students' anxiety levels increased, their listening strategy use decreased and vice versa. Lastly, the data obtained from the interviews presented that the students with higher anxiety levels usually perceived listening difficult and they experienced anxiety when faced a difficulty. On the other hand, the students with lower anxiety levels overcame the difficulties and ambiguities while listening in the target language.

Related to the effects of listening anxiety, Elkhafaifi (2005) conducted a study to present the effect of both general foreign language anxiety on students' achievement in an Arabic course and listening anxiety on students' listening comprehension. Having administered both FLCAS and FLLAS and a background

questionnaire to 233 postsecondary students of Arabic as a foreign language, he explored that FL learning anxiety and listening anxiety are separate but related phenomena that both correlate negatively with achievement. There was a significant positive relationship between FLCAS and FLLAS. In other words, students with higher levels of FL anxiety tended to have higher levels of listening anxiety and vice versa. Next, the results showed a significant negative correlation between listening anxiety and the final listening grade. This indicated that the students with higher anxiety levels had lower listening comprehension grades than the students with lower anxiety levels. Another finding was that there was a small, but statistically significant correlation between listening anxiety and the students' year of postsecondary education. That is to say, students in third-year Arabic had significantly lower levels of listening (Listen = 41.33) than the students in first-year Arabic (Listen = 57.21) and students in second-year Arabic (Listen = 53.66). However, there were no significant differences between the first year and second year Arabic students in terms of listening anxiety. Although the results indicated a significant difference between males and females with respect to their levels of learning anxiety in that, female students were more anxious than male students, there was no significant difference between listening anxiety in terms of gender. Their means of listening anxiety scores were 47,83 for males and 53,62 for females. The females had slightly higher scores than the males. He concluded that reducing anxiety and providing a positive classroom atmosphere are the keys to improve students' listening comprehension proficiency and their course performance.

Similarly, in the study carried out by Horwitz et al. it was stated that anxious students had difficulties both discriminating the sounds and structures and grasping the content of a target language message. They explained this situation as "one male student claims to hear only a loud buzz whenever his teacher speaks the foreign language. ...Many LSC clients claim that they have little or no idea of what the teacher is saying in extended target language utterances" (1986: 126).

## CHAPTER III

### 3. METHODOLOGY

#### 3.1. Research Design

The current study is two-dimensional. It implemented both qualitative and quantitative research design. In the first part, it involves a descriptive analysis of the receptive skills anxiety (reading and listening anxiety) levels of the first year, second year, and third year students. For this reason, two widely accepted questionnaires (FLRAS and FLLAS) were employed. The correlation between FLRAS and FLLAS scores and students' academic status and gender was also analyzed. As learner variables, just gender and academic status were taken into account in quantitative part. In the second part of the study, semi-structured (a closed, fixed-response) interview as a qualitative medium was employed. Making use of a qualitative medium in as exploratory and descriptive research is so important that it supports and strengthens the quantitative results. Students were asked to choose one of the options from pre-identified sources and reducing ways of language anxiety as a source of anxiety and a strategy to cope with this anxiety for them in reading and listening classes. A background questionnaire was designed to capture the background information of the interviewees including their age, academic status, gender, high school, whether they are pleased to be in ELT department or not, purpose of learning English, to which aspects of language they mostly pay attention, how often they read or listen in English, whether they know reading and listening strategies or not, whether they are aware of anxiety in language learning or not.

#### 3.2. Participants

In the present study, there were a total of 159 students from different grades. They were all Turkish undergraduate students majoring in ELT Department of Necmettin Erbakan University in Turkey. With regard to their academic status, 69 (43,4 %) were first year (freshmen), 51 (32,1 %) were second year (sophomores), and the rest 39 (24,5 %) were third year students (juniors). In terms of gender, there were 42 (26,4 %) male students and 117 (73,6 %) female students. The ratio of

females to males for freshmen is 56:13, for sophomores is 30:21, and for juniors is 31:8. The inequality between the number of males and females were due to the natural distribution of the participants in ELT departments. As a limitation of the study in terms of academic status, the fourth year students (seniors) weren't involved in the study as they had their teaching practicum and prepared for the public personal selection examination (KPSS). All of the participants were considered prospective teachers of English as they were majoring in English Language Teaching Department. English majors were chosen because the basic concern of the study was to investigate the anxiety-driven differences associated with reading and listening skills in English.

Table 2. Descriptive statistics of the participants in terms of academic status

Academic Status	Frequency	Percent	Valid Percent	Cumulative Percent
Freshmen (First-year)	69	43,4	43,4	43,4
Sophomores (Second-year)	51	32,1	32,1	75,5
Juniors (Third-year)	39	24,5	24,5	100,0
Total	159	100,0	100,0	

Table 3. Descriptive statistics of the participants in terms of gender

Gender	Frequency	Percent	Valid Percent	Cumulative Percent
Female	117	73,6	73,6	73,6
Male	42	26,4	26,4	100,0
Total	159	100,0	100,0	

### 3.3. Instruments

One reason behind conducting this study is that the studies on language anxiety, especially on specific language skills like reading and listening are too limited to draw conclusions in Turkey. It mainly focuses on identifying the problem from the learners' perspectives. Adopting different kind of data collection measures is of crucial in language learning while doing a research. Therefore, in order to answer the research questions both quantitative and qualitative data collection instruments were used in this study. The quantitative measures were widely accepted questionnaires:

- a) Foreign Language Reading Anxiety Scale (FLRAS) (see Appendix 1),
- b) Foreign Language Listening Anxiety Scale (FLLAS) (see Appendix 2).

For a wider range of insights on sources and reducing ways of foreign language anxiety in receptive skills, qualitative part of the study includes;

- a) Background information questionnaire (see Appendix 3),
- b) Closed and fix-response interviews (see Appendix 4),

#### 3.3.1. Foreign Language Reading Anxiety Scale (FLRAS)

Foreign Language Reading Anxiety Scale (FLRAS) was developed to measure foreign language reading anxiety by Y. Saito, E. K. Horwitz, and T. J. Garza in 1999 and used by many researchers (Wu, 2011; Lien, 2011; Köroğlu, 2010; Şahin, 2011; Song, 2010; Kuru-Gönen, 2005). It contains 20 Likert scale items scored on a 5-point scale with 1 indicating strongly disagree, 2 indicating agree, 3 indicating neither agree nor disagree, 4 indicating agree and 5 indicating strongly agree. Four of the items (items 12, 13, 14, and 18) are worded in non-anxious direction and sixteen items are worded in the anxious direction. Thus, the four items were reverse scored. The theoretical range of the FLRAS scale is from 20 to 100. Lower scores indicate lower reading anxiety and higher scores indicate higher reading anxiety. The FLRAS has proven to be reliable with internal consistency coefficient of 0.86 (Cronbach's alpha, n=33) (Saito et al., 1999). As reported by Saito et al. (1999), the FLRAS has an overall coefficient of  $r=0.64$  ( $p<0.01$ ). It includes various aspects of reading,

students' perceptions of reading difficulties in their target language, and their perceptions of the relative difficulty of reading as compared to the difficulty of other language skills.

Table 4. Descriptive statistics for the FLRAS

FLRAS	N	Minimum	Maximum	Mean	Std. Error	Std. Deviation
	159	28	76	58,77	,620	7,814

FLRAS= Foreign Language Reading Anxiety Scale

For this study, it is also reliable with the internal consistency coefficient of 0.70 (N=159). In the social sciences, acceptable reliability estimates range from .70 to .80 (Nunnally & Bernstein, 1994). Therefore, it shows that FLRAS is reliable for this study. The lowest score was 28 while the highest score was 76 out of 100. The mean score of it was 58.77.

### 3.3.2. Foreign Language Listening Anxiety Scale (FLLAS)

Foreign Language Listening Anxiety Scale (FLLAS) was developed by J. H. Kim in 2000 based on the foreign language anxiety scale (FLCAS) designed by Horwitz et al. in 1986. As a reliable scale, FLLAS was employed in many studies (Kimura, 2008; Bekleyen, 2009; Wang, 2010; Kılıç, 2007). This scale consisting of 33 items is a 5-point Likert type scale with 1 means strongly disagree, 2 means disagree, 3 means neither agree nor disagree, 4 means agree, and 5 means strongly agree. Four of the items (items 6, 14, 25, and 31) are worded in non-anxious direction and twenty nine items are worded in the anxious direction. Thus, the four items were reverse scored. Thus, a lower score indicates a lower level of anxiety whereas a higher score indicates a higher level of anxiety. The possible range of the FLLAS scores is from 33 to 165. The FLLAS showed high reliability. The Cronbach's alpha of its final version was  $r = 0.93$ . The analyses of internal consistency ( $r = .91$ ) and test-retest reliability ( $r = .84$ ). All proved that FLLAS is a reliable measure.

Table 5. Descriptive statistics for the FLLAS

FLLAS	N	Minimum	Maximum	Mean	Std. Error	Std. Deviation
	159	68	141	105.08	1,173	14,789

FLLAS= Foreign Language Listening Anxiety Scale

In this study, it also showed high reliability Cronbach alpha coefficient of 0.86 (N= 159). Minimum score was 68; on the other hand, maximum score was 141 out of 165. The mean score was 105.08. The table above presents the descriptive statistics for the FLLAS.

### 3.3.3. Background Information Questionnaire

A background questionnaire conducted just on the interviewees was designed to capture demographic and specific information including the following: (1) the students' age, (2) the students' gender, (3) the students' type of high school, (4) the students' academic status, (5) whether they like studying in ELT department, (6) the reasons why they learn English, (7) to which aspects of language they mostly pay attention, (8) how often they read or listen something in English, (9) whether they know reading and listening strategies, and (10) whether they are aware of anxiety in language learning (see Appendix C).

### 3.3.4. Semi-Structured (Closed and Fix-response) Interviews

The rationale behind the use of interview as a data source is that it can provide access to things that cannot be directly observed, such as feelings, thoughts, intentions, or beliefs (Denzin, 1989; Merriam, 1998). In other words, interviews allow the researcher to obtain a special kind of information, or what is "in and on someone else's mind" (Patton, 1990: 278). In addition, as one of the aims of this study is to identify the sources of foreign language anxiety in reading and listening skills, interviews were chosen as a means of gathering specific information. In this regard, Young (1991) states that "to discuss what can be done to reduce language anxiety, we must not only identify its sources, but also recognize expressions of stress in learners". For Peacock (1998: 12), interviews act as "back-up data designed to illuminate and explain results obtained from quantitative data."

The researcher employed a semi-structured (closed, fixed-response) interview. It is defined by Nichols (1991: 131) as a survey where “the range of possible answers to each question is known in advance.” Possible answers are pre-identified on the form so that the interviewee simply chooses one of them. All the interviewees are asked the same questions and asked to choose the answers from among the same set of prearranged alternatives. The questions are closed-ended. As drawbacks of it, fixed-response interview lacks of flexibility in that there is “little room for unanticipated discoveries” (Breakwell, Hammond and Fife-Schaw, 1995: 231). Therefore, it is less probing and answers are limited. That is to say, there may not be an appropriate answer for some students. However, in terms of students being able to choose one of the options that are close to them and guiding the students, it is relatively practical.

The reasons behind employing a fixed-response interview in this study are; (a) the information is easily quantifiable and allows the responses to be compared, (b) it is easier to analyze the responses and reach the core of the matter (c), and it is one of the most suitable method to those students who are not used to interviewing and are uncomfortable with it. Because of their being reluctant and keeping themselves apart from interviews, open-ended questions will possibly not be answered as much as these.

All the interviews were recorded and then transcribed. Heritage (1984: 238) suggests that the procedure of recording and transcription interviews has the following advantages:

- It helps to correct the natural limitations of our memories and of the intuitive glosses that we might place on what people say in interviews;
- It allows more thorough examination of what people say;
- It permits repeated examinations of the interviewees' answers;
- It opens up the data to public scrutiny by other researchers, who can evaluate the analysis that is carried out by the original researchers of the data (that is, a secondary analysis);

- It therefore helps to counter accusations that an analysis might have been influenced by a researcher's values or biases;
- It allows the data to be reused in other ways from those intended by the original researcher—for example, in the light of new theoretical ideas or analytic strategies.

The sources and reducing ways of language anxiety in reading and listening classes were identified and arranged on the basis of Vogely (1998) and Young's (1994) studies. The questions have focused on possible sources and reducing ways of language anxiety.

### **3.4. Data Collection Procedure**

The purpose of the present study is (a) to investigate the relationship between receptive skills anxiety (reading and listening anxiety) and gender and academic status of the Turkish EFL learners and (b) to identify the possible sources and reducing ways of language anxiety in reading and listening classes from the students' perspectives. To accomplish these purposes, various types of data were collected in the study: participants' FLRAS and FLLAS scores, a background questionnaire, and a semi-structured (fixed-response) interview.

Potential participants of the study were both daytime education and evening students. In this study, the researcher conducted the study on just the daytime students as there may be some slight differences between daytime and evening education students. Moreover, this will provide more standard and reliable data for the study.

The data were collected in ELT departments of Necmettin Erbakan University in the second, third, and fourth weeks of November, 2011. Both FLRAS and FLLAS were administered to each group at the same time. To create a secure and sincere environment, the researcher informed the students about the nature of the study. First of all, 69 freshmen as daytime group completed the questionnaires with the permission of their instructor. It lasted to complete both of the questionnaires about 40 minutes in each class. Then, 51 sophomore students were asked to answer

the questionnaires in class time. Lastly, the 39 junior students completed the FLRAS and FLLAS as a first step of the study.

In the second and third weeks of November, the eight selected participants from each class (3 males and 3 females), a total of 18 students, who were classified as highly anxious based on their FLRAS and FLLAS scores were invited to the individual interview (the scores between 80-100 are accepted as high for FLRAS and 132-165 for FLLAS). As a first step of the interviews, the participants were asked to fill a background questionnaire which contains some specific questions about their background like their high school, age, academic status, etc. Then, the subjects took part in the interview about their feelings on the sources and reducing ways of reading and listening anxiety. The researcher asked the pre-identified questions and they chose the best option for them. All of the interviews were recorded and transcribed for analysis.

### **3.5. Data Analysis**

The first step of data analysis was to compute the entire sample's (N=159) responses to the Foreign Language Reading Anxiety Scale (FLRAS) and Foreign Language Listening Anxiety Scale (FLLAS) in terms of mean score, standard deviation, frequency, correlation methods, and percentage. ANOVA and T-Test were used to detect how different background variables were related to the foreign language reading anxiety and foreign language listening anxiety levels of the participants. Microsoft Excel 2010 was used to input the scores of the FLRAS and FLLAS to format the background information of the participants. These data then were exported to another statistical program, the SPSS 15.0 for PC to compute descriptive statistics. As mentioned above, a five-point Likert-type scale ranging from "1= strongly disagree" to "5= strongly agree" was used in both questionnaires. The lower scores indicated lower levels of anxiety. However, negatively worded statements were reverse-scored so that a response of "strongly agree" always indicated high levels of anxiety. For instance, the 12<sup>th</sup> item "I enjoy reading English", the 13<sup>th</sup> item "I feel confident when I am reading in English", the 14<sup>th</sup> item "Once I get used to it, reading English is not so difficult", and the 18<sup>th</sup> item "I am satisfied

with the level of reading ability in English that I have achieved so far” in the FLRAS were reverse-scored. That is, if the students scored 1=strongly disagree, it would be evaluated as 5= strongly agree. As for the FLLAS, the 6<sup>th</sup> item “It is easy to guess about the parts that I miss while listening to English”, the 14<sup>th</sup> item “I feel confident when I am listening in English”, the 25<sup>th</sup> item “I have no fear of listening to English as a member of an audience”, and the 31<sup>st</sup> item “English stress and intonation seem familiar to me” were reverse-scored.

Qualitative data were gathered through the semi-structured interviews. The participants for the interviews were 24 students. They were highly anxious 4 male and 4 female students from each class. The researcher asked the questions about the possible sources and reducing ways of language anxiety in reading and listening classes. The participants chose the best answers from the pre-identified options. During the interview, the data was audio-recorded and later transcribed. The researcher read the transcribed text and analyzed according to the questions. The similarities and differences in the responses were taken into account by the researcher and discussed in the result section.

Finally, the data gathered through interview was analyzed together with the background information questionnaire.

## CHAPTER IV

### 4. RESULTS OF THE STUDY

This chapter was designed to explore Turkish EFL learners' receptive language skills anxiety. Besides, possible sources of reading and listening anxiety and strategies to reduce it were also investigated. It attempted to argue what extent the learners of English experienced reading and listening anxiety and show whether there was a relationship between reading and listening anxiety levels of learners. Regarding the background variables including students' gender and academic status, this study conducted to shed light on language anxiety in terms of receptive language skills. It was tried to answer the following research questions;

1. To what extent do Turkish ELT students experience receptive language skills anxiety (foreign language reading and foreign language listening anxiety)?
2. Is there a relationship between foreign language reading anxiety and foreign language listening anxiety levels of the students?
3. Is there a statistically significant difference between the students' receptive skills anxiety in terms of their gender and academic status?
4. Which factors do students believe contribute to anxiety?
5. Which factors do students believe may help to reduce anxiety?

The first research question was answered by the data gathered through quantitative ways and correlation analysis between FLRAS and FLLAS. The second research question was answered by T-test and ANOVA methods. The third and fourth research questions were answered through the qualitative data collected through interviews.

#### 4.1. Analysis of the Research Question 1

*To what extent do Turkish ELT students experience receptive language skills anxiety (foreign language reading and foreign language listening anxiety)?*

The first research question is based on a descriptive analysis of the FLRAS and FLLAS results. The students' responses to the FLRAS and FLLAS were transferred to numerical values, ranging from 1=strongly disagree to 5=strongly agree. The items 12, 13, 14, and 18 in the FLRAS and the items 6, 14, 25, and 31 in the FLLAS that contained the non-anxious side were reverse-scored, so that a high score on the FLRAS and FLLAS represents high levels of reading and listening anxiety. The theoretical ranges of the scales were 20-100 for the FLRAS and 33-165 for the FLLAS.

First, the scores of all the subjects (N=159) were summed to calculate the mean scores of the students. Analysis of the FLRAS revealed that the mean score for the entire group of 159 subjects was 58,77 with standard deviation of 7,814, ranging from 28 to 76. This indicated that there is fair amount of foreign language reading anxiety among Turkish EFL learners. Next, analysis of the FLLAS revealed that the mean score for the entire group of 159 participants was 105,08 (63,68 %) with standard deviation of 14,789, ranging from 68 to 141. This showed that the students experienced average level of foreign language listening anxiety. When compared the mean scores of FLRAS and FLLAS, participants reported slightly more listening anxiety than reading anxiety. The Table 5 below displays the descriptive statistics for the FLRAS and FLLAS of 159 students.

Table 6. Descriptive statistics for the FLRAS and FLLAS

	N	Minimum	Maximum	Mean	Std. Error	Std. Deviation
FLRAS	159	28	76	58,77	,620	7,814
FLLAS	159	68	141	105,08	1,173	14,789

#### 4.2. Analysis of the Research Question 2

*Is there a relationship between foreign language reading anxiety and foreign language listening anxiety levels of the students?*

As for the second research question, the Pearson Correlation was calculated to find out the relationship between overall foreign language reading anxiety and foreign language listening anxiety means.

Table 7. The Pearson's r correlation between reading anxiety and listening anxiety levels

Variable	Reading Anxiety	Listening Anxiety
Reading Anxiety	-	,374(**)
Listening Anxiety	,374(**)	-

\*\* Correlation is significant at the 0.01 level (2-tailed).

As the Table 7 above presents, the Pearson's r indicated a moderate positive relationship between the two scales ( $r = .374$ ,  $p < .01$ ). This reveals that students with higher levels of reading anxiety also had higher levels of listening anxiety or vice versa.

#### 4.3. Analysis of the Research Question 3

*Is there a statistically significant difference between the students' receptive language skills anxiety in terms of their gender and academic status?*

Figure 4. The role of gender on receptive language skills

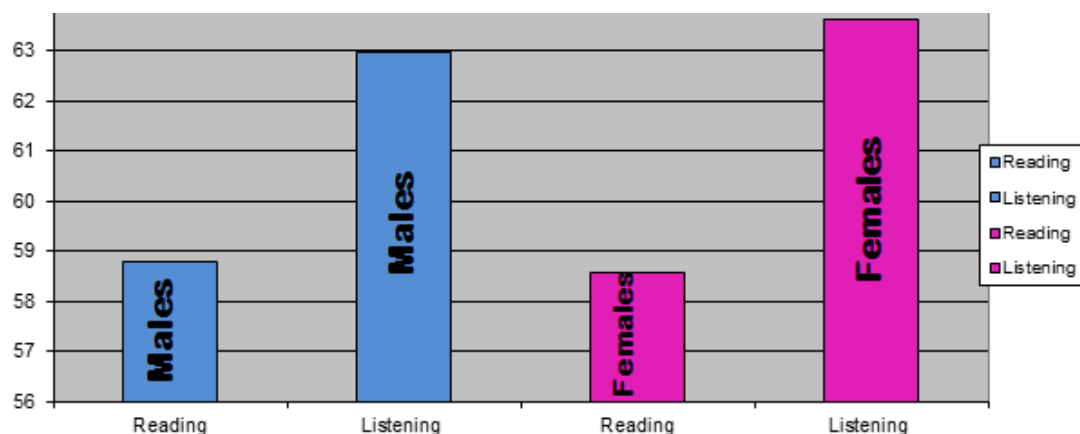

The relationship between overall foreign language reading anxiety and gender was analyzed by an independent *t*-test. The mean scores for males (N=42) and females (N=117) were 59,31 and 58,57, respectively. This difference was not statistically significant ( $t=-.523$ ,  $p=.602$ ). This indicated that there was no difference in terms of gender in reading anxiety among Turkish EFL learners. The results are displayed in Table 8 below.

Table 8. The results of the independent samples *t*-test of male vs. female differences on the FLRAS scores

Scale	Gender	N	M	SD	t	p
FLRAS	Male	42	59,31	9,142	-,523	,602
	Female	117	58,57	7,314		

Similarly, an independent *t*-test was employed to determine the relationship between students overall foreign language listening anxiety levels and their gender. The mean scores for males (N=42) and females (N=117) were 102, 52 and 105, 99, respectively. It was no surprise that no significant correlation found between the levels of listening anxiety and gender. The difference was not statistically significant ( $t= 1,306$ ,  $p=, 193$ ). This indicated that male and female students had a similar amount of anxiety in EFL context. The results are presented in Table 9 below.

Table 9. The results of the independent samples *t*-test of male vs. female differences on the FLLAS scores

Scale	Gender	N	M	SD	t	p
FLLAS	Male	42	102,52	13,380	1,306	,193
	Female	117	105,99	15,212		

However, when it was examined more specifically, there existed differences in terms of gender between both reading anxiety and listening anxiety among the first year students (freshmen). For reading, the mean scores for males (N=13) and females (N=56) were 53,85 and 58,71, respectively. The difference was significant ( $t= 2,026$ ,  $p= ,047$ , ( $p<0,05$ )). Again for listening, the mean scores for males (N=13) and females (N=56) were 96,54 and 108,84, respectively. There was a significant difference between listening anxiety and gender among first year students at the 0.05 level ( $t= 2,581$ ,  $p=,012$ ). Table 10 showed the results below.

Table 10. Differences in terms of gender on reading and listening anxiety among freshmen

Scales	Gender	N	M	SD	t	p
Reading	Male	13	53,85	10,278	2,026	,047
	Female	56	58,71	7,152		
Listening	Male	13	96,54	16,566	2,581	,012
	Female	56	108,84	15,234		

On the other hand, the second year students (sophomores) showed no significant difference in terms of gender on reading and listening anxiety. The results procured from t-test analysis revealed no significant difference between gender and both reading and listening anxiety scores among sophomores. The mean scores for males (N=21) and females (N=30) were 62,38 and 60,23 for reading, respectively. For listening, they were 104,24 for males and 102,63 for females. The differences were not statistically significant ( $t= -1,128$ ,  $p= ,265$ ) for reading and ( $t= -,426$ ,  $p= ,672$ ) for listening. This indicated no difference in terms of gender in reading and listening anxiety among the second year EFL learners. The results are displayed in Table 10 below.

Table 11. Differences in terms of gender on reading and listening anxiety among sophomores

Scales	Gender	N	M	SD	t	p
Reading	Male	21	62,38	6,667	-1,128	,265
	Female	30	60,23	6,704		

Listening	Male	21	104,24	9,197	-,426	,672
	Female	30	102,63	15,419		

Likewise, there was no significant difference between gender and reading/listening anxiety levels of junior students. The mean scores for males (N=8) and females (N=31) were 60,13 and 56,71 for reading, respectively. For listening, they were 104,13 for males and 100,81 for females. The differences were not statistically significant ( $t = -1,032$ ,  $p = ,309$ ) for reading and ( $t = -,588$ ,  $p = ,560$ ) for listening. The results displayed in the Table 11 showed no difference in terms of gender in reading and listening anxiety among the third year EFL learners.

Table 12. Differences in terms of gender on reading and listening anxiety among juniors

Scales	Gender	N	M	SD	t	p
Reading	Male	8	60,13	9,848	-1,032	,309
	Female	31	56,71	7,951		
Listening	Male	8	104,13	14,662	-,588	,560
	Female	31	100,81	14,134		

Figure 5. The role of grade level on receptive language skills

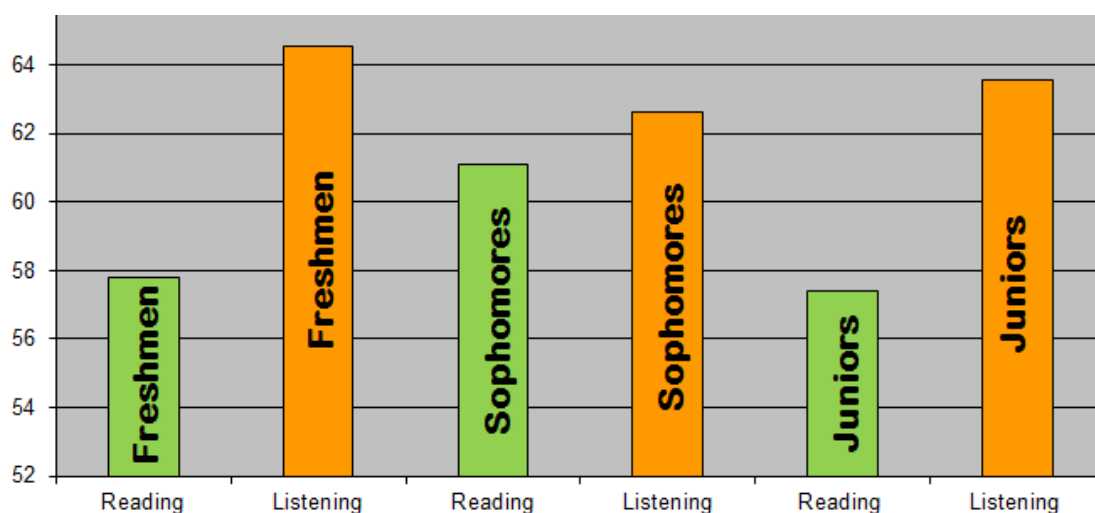

To determine whether the learners' reading and listening anxiety levels differed in terms of their academic status, a one-way ANOVA was used. The results

were inconsistent (see Table 10, 11, and 12). The results revealed that there was no significant difference between participants' listening anxiety levels and their academic status. That is to say, whether the learners were freshmen, sophomores, or juniors it didn't affect their scores of listening anxiety. On the other hand, it was explored that there was a significant difference between reading anxiety scores and the participants' academic status ( $p < 0,05$ ). A multivariate Tukey test was used in order to determine the group that causes the difference. The findings elicited from the Tukey test revealed that there was a moderately significant difference between reading anxiety scores of sophomores and juniors. In other words, students who were in the second year in ELT department had moderately higher levels of reading anxiety than those in the third year. The results are presented in the Tables 13, 14, and 15.

Table 13. Descriptive statistics of reading and listening differences on academic status

Scales	Class	N	M	SD	Std. Error
Reading	First year	69	57,80	7,981	,961
	Second year	51	61,12	6,707	,939
	Third year	39	57,41	8,350	1,337
Listening	First year	69	106,52	16,112	1,940
	Second year	51	103,29	13,129	1,838
	Third year	39	104,85	14,487	2,320

To check whether these differences in the score mean in terms of different academic status statistically significant or not, variance analysis was employed on the group means. The results were displayed in Table 14.

Table 14. ANOVA results of FLRAS and FLLAS according to students' academic status

Scales	Source of variance	Sum of Squares	df	Mean Square	F	p
Reading Anxiety	Between Groups	418,501	2	209,250	3,537	,031

	Within Groups	9229,889	156	59,166		
	Total	9648,390	158			
Listening Anxiety	Between Groups	308,212	2	154,106	,702	,497
	Within Groups	34246,883	156	219,531		
	Total	34555,094	158			

According to the Table 14 above, F is 3,537 ( $p=,031$ ) for reading and F is ,702 ( $p=,497$ ) for listening. To these results, there is a significant difference for reading anxiety in terms of the scores between groups while there is no significant difference for listening anxiety in terms of the scores between groups. To determine the variance which causes this difference, the Tukey Test was employed. The results were shown in Table 15 below.

Table 15. The sources of the difference between reading anxiety and listening anxiety in terms of academic status

Post-Hoc Tukey HSD

Scales	Class	First year	Second year	Third year
Reading	First year	-	-3,321	,387
	Second year	3,321	-	3,707
	Third year	-,387	-3,707	-
Listening	First year	-	3,228	1,676
	Second year	3,228	-	1,552
	Third year	-1,676	1,552	-

Although as shown in Table 14, ANOVA results have indicated a slight difference for reading anxiety in terms of the scores between groups, Post-Hoc Tukey Test didn't show any sources that cause that difference (see Table 15). A possible reason of this may be the proximity of the scores of the students. That is to say, there is a difference but it is not meaningful.

#### 4.4. Analysis of the Research Question 4

##### *Which factors do students believe contribute to anxiety?*

To determine the possible sources of language anxiety, a fixed-response as a semi-structured interview was employed as a qualitative data medium. The data audio-recorded and later transcribed to be analyzed in detail. Each interview lasted about 5-7 minutes. Three males and three females were chosen from each grade level. That is, they were three highly anxious male freshmen, three highly anxious female freshmen, three highly anxious male sophomores, three highly anxious female sophomores, three highly anxious male juniors, and three highly anxious female juniors. The interview questions asked to the interviewees were as follows;

1. How do you feel in your Reading /Listening classes?

- Fully concentrated
- Stressful / Anxious
- Not fully concentrated

2. What is the role of the instructor/teacher in Reading / Listening classes?

.....

3. Which component of the Reading class does cause most anxiety for you?

- I think it results from the learner
- I think it stems from the instructor / lecturer /mentors
- The reading text causes anxiety
- The reading process is the cause of anxiety

4. Which component of the Listening class does cause most anxiety for you?

- It arises from the learner / students
- The instructors / teachers are the reason of anxiety
- The listening process is the main reason
- I think the listening text does
- The interlocutor / speaker causes most anxiety

5. Associated with the **learner**, which factor do you believe may cause anxiety most?

- Linguistic incapability
- Cognitive inability

- Lack of motivation /self esteem
- Cultural beliefs / attitudes
- Fear of failure/making mistake
- Competitiveness
- High expectations/perfectionism
- Negative classroom experiences

6. Associated with the **instructor**, which factor do you believe may cause anxiety most?

- Interaction with the learners / Attitudes
- Error correction/feedback
- Classroom management
- High expectations / Perfectionism
- Unsympathetic personality

7. Associated with the **reading / listening text**, which factor do you believe may cause anxiety most?

- Unknown grammatical structures /words
- Format of the text (clarity, length, visual aids)
- Topic of the text (inauthenticity, unfamiliarity, lack of background information)

8. Associated with the **reading / listening process**, which factor do you believe may cause anxiety most?

- Methodology (methods, strategies, program)
- Uncomfortable/insecure classroom environment
- Classroom activities (public speaking, presentations)
- Evaluation (test types, exams)

9. Associated with the speaker/interlocutor, which factor do you believe may cause anxiety most?

- Speech (pronunciation, intonation)
- Number of speakers
- Gender of the speaker
- Nationality of the speaker

10. Which factor do you believe is more important to cope with Reading / Listening anxiety?

- The learners/students
- The reading/listening process
- The instructors/teachers

11. Which strategy do you believe can be used successfully to reduce Reading / Listening anxiety associated with the learner?

- Cognitive strategies (positive thinking, peer-seeking)
- Affective strategies (deep breathing, motivate yourself, try to calm down)

- Behavioral strategies (improve language learning strategies, preparation, studying)

12. Which factor do you believe is more important to cope with Reading / Listening anxiety associated with the instructor?

- Creating friendly/secure classroom environment
- Teaching language learning strategies
- Raise awareness (talking about anxiety)
- Outline course objectives regularly
- Giving positive feedback

13. Which factor do you believe is more important to cope with the Reading / Listening anxiety associated with the reading / listening process?

- Pedagogical practices (pair and small group work)
- Classroom environment
- Evaluation (testing)
- Choosing the text (to be involved in decision making process)

As a first question, the students were asked how they felt in their reading and listening classes. As general, out of 18 students, 9 students (50%) stated as stressful or anxious in their reading and listening classes. 9 (50%) of them said they were not fully concentrated their classes. None of them was fully concentrated (see Table 16).

Table 16. Descriptive statistics of the first interview question

How do you feel in your Reading /Listening classes?	Freshmen				Sophomores				Juniors			
	Males		Females		Males		Females		Males		Females	
	f	%	f	%	f	%	f	%	f	%	f	%
Fully concentrated	0	0	0	0	0	0	0	0	0	0	0	0
Not fully concentrated	1	33	1	33	1	33	2	66	2	66	2	66
Stressful/Anxious	2	66	2	66	2	66	1	33	1	33	1	33

The second question was about the role of the teacher in reading and listening classes. 12 students (67%) stated that teacher was a guider and leader in reading and listening activities. 4 students (22%) expected teacher to help them while doing reading and listening activities. Only 2 students (11%) hoped to be taught new things by their teacher.

Table 17. Descriptive statistics of the second interview question

What is the role of the instructor in Reading / Listening classes?	Freshmen				Sophomores				Juniors			
	Males		Females		Males		Females		Males		Females	
	f	%	f	%	f	%	f	%	f	%	f	%
Guider / leader	2	66	1	33	3	100	1	33	2	66	3	100
To help students	0	0	1	33	0	0	2	66	1	33	0	0
Teaching new things	1	33	1	33	0	0	0	0	0	0	0	0

The third question was about the potential causes of anxiety in reading classes. 12 students (67%) expressed that the learners were the main causes of reading anxiety. 3 learners (17%) considered the instructor as the cause of anxiety in reading classes. 2 participants (11%) were agreed on the reading text as a source of anxiety. Only one learner (5%) chose the reading text (see Table 18).

Table 18. Descriptive statistics of the third interview question

Sources of Anxiety Which component of the Reading class does cause most anxiety for you?	Freshmen				Sophomores				Juniors			
	Males		Females		Males		Females		Males		Females	
	f	%	f	%	f	%	f	%	f	%	f	%
The learner	2	66	1	33	2	66	2	66	3	100	2	66
The instructor	1	33	1	33	0	0	0	0	0	0	1	33
The reading text	0	0	1	33	0	0	1	33	0	0	0	0

The reading process	0	0	0	0	1	33	0	0	0	0	0	0
---------------------	---	---	---	---	---	----	---	---	---	---	---	---

The fourth question was “which component of the listening class does cause most anxiety for you?” Like in reading, 10 subjects (56%) accepted themselves as the main source of anxiety in listening classes. Only one student (6%) saw the instructor as a cause of anxiety. The listening process was the main cause of listening anxiety for 5 participants (28%). The listening text and speaker were seen the causes of anxiety by 2 learners (see Table 19).

Table 19. Descriptive statistics of the fourth interview question

Sources of Anxiety	Freshmen				Sophomores				Juniors			
Which component of the Listening class does cause most anxiety for you?	Males		Females		Males		Females		Males		Females	
	f	%	f	%	f	%	f	%	f	%	f	%
	The learner	0	0	0	0	2	66	3	100	3	100	2
The instructor	0	0	1	33	0	0	0	0	0	0	0	0
Listening process	3	100	0	0	1	33	0	0	0	0	1	33
Listening text	0	0	1	33	0	0	0	0	0	0	0	0
Speaker/interlocutor	0	0	1	33	0	0	0	0	0	0	0	0

“Associated with the learner, which factor do you believe may cause anxiety most?” was the fifth interview question. Overwhelmingly, fear of failure / making mistake was accepted as the main cause of anxiety associated with the learner in reading and listening process by 13 learners (72%). 3 students (17%) opted lack of motivation / self-esteem. The rest (11%) agreed on high expectations / perfectionism as the source of anxiety related to the learner (see Table 20).



Error correction /feedback	2	66	2	66	1	33	1	33	1	33	2	66
Classroom management	0	0	0	0	1	33	1	33	1	33	1	33
Interaction with the learners	0	0	0	0	1	33	0	0	1	33	0	0
Unsympathetic personality	0	0	0	0	0	0	0	0	0	0	0	0
High expectations / Perfectionism	1	33	1	33	0	0	1	33	0	0	0	0

“Associated with the reading / listening text, which factor do you believe may cause anxiety most?” was the seventh interview question. 11 out of 18 students (61%) opted topic of the text as the main source of anxiety. Unknown grammatical structures / words were the cause of reading/listening anxiety for 7 learners (39%) (see Table 22).

Table 22. Descriptive statistics of the seventh interview question

Sources of Anxiety	Freshmen				Sophomores				Juniors			
	Males		Females		Males		Females		Males		Females	
	f	%	f	%	f	%	f	%	f	%	f	%
	Associated with the <b>reading / listening text</b> , which factor do you believe may cause anxiety most?											
Unknown grammatical structures /words	2	66	2	66	1	33	0	0	1	33	1	33
Format of the text	0	0	0	0	0	0	0	0	0	0	0	0
Topic of the text	1	33	1	33	2	66	3	100	2	66	2	66

The eighth interview question was about the characteristics of the reading / listening process that provoked anxiety in reading and listening classes. Almost half of the participants (44%) chose classroom activities that produce anxiety. 5 students (28%) thought evaluation in reading and listening classes as producing anxiety. 4 people (22%) complained about the uncomfortable classroom environment. Only one learner (6%) wasn't pleased with the methodology (see Table 23).



#### 4.5. Analysis of the Research Question 5

##### *Which factors do students believe may help to reduce anxiety?*

As reducing ways of reading and listening anxiety, the researchers prepared the interview questions based on three general factors: the learner, the instructor, and the reading/listening process.

“Which factor do you believe is more important to cope with Reading / Listening anxiety?” was the tenth interview question. 7 out of 18 people (39%) opted the learners as the main factor to cope with reading and listening anxiety. The instructor may reduce anxiety according to 5 students (28%). 6 participants (33%) were of the same opinion that the reading and listening process should be taken into account to deal with anxiety.

Table 25. Descriptive statistics of the tenth interview question

Ways of reducing anxiety	Freshmen				Sophomores				Juniors			
	Males		Females		Males		Females		Males		Females	
	f	%	f	%	f	%	f	%	f	%	f	%
Which factor do you believe is more important to cope with Reading / Listening anxiety												
The learners	0	0	1	33	2	66	3	100	1	33	0	0
The instructors	3	100	2	66	0	0	0	0	0	0	0	0
The reading /listening process	0	0	0	0	1	33	0	0	2	66	3	100

The eleventh question was about the characteristics of the learner to cope with anxiety in reading/listening classes. 10 students (56%) chose the cognitive strategies to cope with anxiety. 8 of them (44%) brought on the affective strategies. There was no one to choose the behavioral strategies (see Table 26).

Table 26. Descriptive statistics of the eleventh interview question

Ways of reducing anxiety	Freshmen				Sophomores				Juniors			
	Males		Females		Males		Females		Males		Females	
	f	%	f	%	f	%	f	%	f	%	f	%
Which strategy do you believe can be used successfully to reduce Reading / Listening anxiety associated with the learner?												
Cognitive strategies	3	100	0	0	3	100	1	33	2	66	1	33
Affective strategies	0	0	3	100	0	0	2	66	1	33	2	66
Behavioral strategies	0	0	0	0	0	0	0	0	0	0	0	0

“Which factor do you believe is more important to cope with Reading / Listening anxiety associated with the instructor?” was the twelfth question. 6 subjects (33%) were of the same opinion that the instructor should create a friendly classroom environment. 5 people (28%) suggested teaching language learning strategies. The instructor’s giving positive feedback was focused on by 7 students (39%) (See Table 27).

Table 27. Descriptive statistics of the twelfth interview question

Ways of reducing anxiety	Freshmen				Sophomores				Juniors			
	Males		Females		Males		Females		Males		Females	
	f	%	f	%	f	%	f	%	f	%	f	%
Which factor do you believe is more important to cope with Reading / Listening anxiety associated with the instructor?												
Creating friendly classroom environment	0	0	0	0	1	33	2	66	1	33	2	66
Teaching language learning strategies	1	33	2	66	1	33	1	33	0	0	0	0
Raising awareness	0	0	0	0	0	0	0	0	0	0	0	0
Outlining course objectives regularly	0	0	0	0	0	0	0	0	0	0	0	0
Giving positive feedback	2	66	1	33	1	33	0	0	2	66	1	33



4. How often do you read or listen something?

- Always                       Usually                       Sometimes                       Rarely  
 Never

5. Do you know Reading / Listening strategies?

- Yes                       Some                       No

6. Have you heard about stress or anxiety in language learning?

- Yes                       No

A total of 18 participants were between 18 and 27. 3 male and 3 female students were from first grade, 3 male and female students were from the second grade, and 3 male and female students were from the third grade. 3 students were from regular high school, 5 of them were from Anatolian high school, 9 participants were from Anatolian teacher training high school, and 1 of them was from a private college. For the first question, 14 of them opted “yes” while 4 of them chose “I’m not sure”. For the second question, 13 of them learnt English for “job opportunities”, 4 students chose “interest”, and 1 learner chose “academic career”. For the third question, 11 students agreed on “communication”, 2 of them opted “comprehension”, 2 of them selected “pronunciation”, 2 of them chose “grammar”, and 1 of them opted “vocabulary”. As for the fourth question, 9 of them “usually” read and listen, 7 students “sometimes” read and listen, and 2 learners “rarely” read and listen. For the fifth question, 4 learners opted “no” and 14 learners know “some” of the reading/listening strategies. As for the last question, 14 of them heard about stress or anxiety in language learning and 4 of them didn’t hear about stress or anxiety in language learning.

## CHAPTER V

### 5. DISCUSSION AND CONCLUSIONS

This chapter first lists the hypotheses of the researcher for this study and then discusses the findings for each question. This is followed by some limitations of the study, implications for future research and recommendations, and conclusions.

#### 5.1. Discussion

The current study was a descriptive study which investigated the foreign language reading and foreign language listening anxiety levels of Turkish EFL learners in Konya Necmettin Erbakan University with the participation of 159 first (freshmen), second (sophomores), and third year students (juniors). In addition, it attempted to identify the possible sources of language anxiety and reducing ways of this kind of anxiety in reading and listening classes. For this, both quantitative and qualitative data collection measures were employed including a FLRAS, a FLLAS, a semi-structured interview, and a background questionnaire.

Before conducting this study, the researcher had hypothesized the following sentences;

1. Contrary to the common sense that only production skills are adversely affected by language anxiety, this study will reveal that language anxiety harms the receptive language skills.
2. As both are receptive skills, there will be no significant difference between language anxiety in reading skill and listening skill in terms of students' language anxiety levels. However, the students may have higher levels of listening anxiety than reading anxiety as the former one is mostly neglected in many schools.
3. There will be a relationship between gender and reading/listening anxiety. Female students will have higher levels of reading and listening anxiety than male students.

4. There will be a negative relationship between language anxiety in reading and listening classes and students' academic status. That is, the first-year students will have higher levels of anxiety than the second and third year students.

It is mostly assumed that knowing a language means using it productively. Because of this wrong assumption, only production skill: speaking and writing are thought to be negatively affected by language anxiety. Many researchers (Horwitz et al., 1986; Phillips, 1990; Price, 1991; MacIntyre and Gardner, 1991; Young, 1992) have accepted speaking as problematic and extremely anxiety-provoking, and therefore the most challenging aspect in foreign/second language learning. Furthermore, reading and listening are seen as passive skills. Unlike this misbelief, these skills demand cognitive processes. Sellers (2000: 513) claimed that;

We do know that reading in any language is a cognitively demanding process, involving minimally the coordination of attention, memorization, perception, and comprehension processes. The reading process is further complicated in the second language, where there are additional factors to consider such as language ability, cultural backgrounds, and learner motivations, among others.

Also, listening requires spontaneous cognitive process of input. Therefore, it is considered to be the one of the most important part of the oral communication.

As to the findings of present study, it proved that the learners of English experienced moderate level of reading and listening anxiety. Their mean scores for reading and listening were 58,77 and 63,68, respectively. The mean score of reading anxiety echoes similar findings reported in the literature. Song (2010) measured the mean of reading anxiety through FLRAS. The participants were 45 Korean students of English. The author calculated the mean as 54.81. Saito et al. (1999), who devised FLRAS, investigated their French, Japanese, and Spanish students' levels of foreign language reading anxiety. They found 53.14, 56.00, and 47.64, respectively. In

Pichette's (2009) study, the mean scores of learners of English and learners of Spanish were 48.08 and 46.40, respectively. As for the studies that conducted in Turkey, Koroğlu (2010) measured the mean score of his 113 university students' reading anxiety levels as 56.4 (for per item 2.82). Kuru-Gönen (2005) explored that her 50 students experienced moderate level of reading anxiety with a mean of 47.2 (2.36 for per item). All these findings including ours conform that reading anxiety exist as a separate and distinguishable phenomenon. The researcher measured the mean of listening anxiety as 105,08 (63.68%). It was slightly higher than the mean of reading anxiety. When we examine the literature, Kimura (2008) investigated foreign language listening anxiety among 452 Japanese learners and explored the mean of 92,83 (56.26%). In another study, Bekleyen (2009) conducted a study among 84 teacher candidates and measured their mean scores of listening anxiety as 95,30 (57.75). Ko (2010) carried out a study with the participation of 66 Korean college students of English. The mean score of listening anxiety was 59,82 (%). Elkhafafi (2005) investigated the listening anxiety of 453 learners of Arabic through a 20 item Likert type scale devised by him. He found that the students mean score of listening anxiety was 55.47. The mean score of listening anxiety in this study was a bit higher than those of mentioned studies. One possible reason of it is that the Turkish students learn English in EFL context. They don't have enough opportunities to practice it as in the ESL context. All in all, this study and the studies in literature proposed that the phenomena reading and listening anxieties should be studied and taken into account besides speaking.

As to our second assumption, there must be a correlation between reading anxiety and listening anxiety as they are both receptive skills. As a background, all the participants were thought reading and listening courses in their academic status in the department. The Pearson  $r$  indicated a moderately positive relationship between the two scales ( $r = .374$ ,  $p < .01$ ). This reveals that students with higher levels of reading anxiety also had higher levels of listening anxiety or vice versa. Similarly, Merç (2009) investigated the relationship between Turkish EFL learners' foreign language listening anxiety and foreign language reading anxiety. He found that the mean scores for reading anxiety and listening anxiety were 56.8 and 64, respectively.

These scores are almost the same as our findings. Merç reported that the Pearson  $r$  indicated a significant positive relationship between the two scales ( $r = .624$ ,  $p < .01$ ). This was to say, the students with higher reading anxiety also had higher listening anxiety or vice versa. The main possible explanation of this correlation is that these two skills involve the receptive side of language as oral and written. From this point of view, there must be a relationship between them. They are related to each other as each is concerned with the decoding half of the communication process (Devine, 1967). There were some studies to demonstrate a statistical relationship between listening and reading; but they did not completely support this assumption. Devine stated that “reported correlation coefficients between listening and reading were positive and high: Ross (1964) found a coefficient of 0.74; Brown (1965) found coefficients of 0.82 at fourth-grade level, of 0.76 at fifth-grade level, and 0.77 at sixth-grade level; both Condon (1965) and Duker (1965) reported an average coefficient of 0.57” (1967: 154). On the other hand, Lewis (1963) employed listening exercises with college freshmen and did not find any significant differences between listening and reading scores. Merç’s findings showed that the mean score of listening anxiety was higher than that of reading anxiety, too. One of the possible reasons of it, I think, is that listening is the most neglected skill besides speaking in foreign language teaching in Turkey, where the students learn English in EFL context. In other words, the learners of English don’t have enough opportunity to access the authentic listening input. Another possible reasons for high anxiety may be as Christenberry (2001, cited in Merç, 2009) stated listening was a problematic skill for both learners and teachers. Furthermore, listening skill differs from reading skill as the former requires spontaneous process of input. The learners do not have chance to turn back when they don’t understand something while listening someone. On the other hand, in reading, the learner has something concrete in his/her hand to read.

The third expectation of the researcher was that there would be a relationship between gender and reading/listening anxiety. Female students would have higher levels of reading and listening anxiety than those of male students. The researcher had imagined that as they are more emotional than males, female students might be affected more negatively than male students. Having analyzed the data through an

independent sample t-test method, the researcher found the mean scores of reading anxiety as 59.31 and 58.57 for males and females, respectively. The difference was not statistically significant ( $t = -.523$ ,  $p = .602$ ). This indicated that there was no difference in terms of gender in reading anxiety among Turkish EFL learners. Similarly, an independent t-test was employed to determine the relationship between students overall foreign language listening anxiety levels and their gender. The mean scores for males ( $N=42$ ) and females ( $N=117$ ) were 102, 52 and 105, 99, respectively. It was no surprise that no significant difference found between the levels of listening anxiety and gender. The difference was not statistically significant ( $t = 1,306$ ,  $p = .193$ ). This indicated that male and female students had a similar and fair amount of anxiety in EFL context. The findings of this study corroborate with the study conducted among Chinese EFL learners by Shi and Liu (2006). They found that there was no significant difference in terms of gender in foreign language classroom anxiety. This finding is similar to the findings of Aida (2004) who found no difference in terms of gender in foreign language classroom anxiety among learners of Japanese. Similarly, in Campbell's (1999) study, the males and the females had equal listening anxiety two weeks before the course and after the course very minimal difference in terms of gender was explored. Furthermore, Koroğlu (2010) reported that there was not a gender effect on the FLRAS score. Kılıç (2007) put forward that the difference between males and females in terms of both foreign language classroom anxiety and foreign language listening anxiety was not significant. Thus, gender was not a distinctive factor for FLCA and FLLA. In another study conducted on listening anxiety, Elkhafafi (2005) found no significant difference between listening anxiety and gender. Recently, Wu (2011) revealed that both language anxiety and reading anxiety did not differ significantly across gender. That is, no significant difference found between males and females. On the other hand, the finding of the current study contradicts some of the studies. For example, Abu-Rabia (2004) found that female students had higher foreign language anxiety level than male students. In her study, the participants were seventh graders in Israel learning English as a second language. Similarly, Elkhafafi (2005) uncovered significant difference between males and females in their levels of learning anxiety,

with females being more anxious than males. Likewise, Zhang (2000) investigated the reading anxiety through both qualitative and quantitative means among 145 intermediate level Chinese students studying in Singapore. The results of the study showed that male and female learners experience different levels of anxiety. The female learners experienced more anxiety than their male counterparts. In a similar way, Matsuda & Gobel (2004) investigated the relationship between foreign language classroom anxiety and foreign language reading anxiety and variables of gender and extended overseas experience. The researchers identified that gender was found to be one of the most significant indicators of performance in foreign language performance. Cheng (2002) reported that Taiwanese female students of English had higher levels of writing anxiety than male students. Lastly, in a recent study, Wilson (2006) explored that female students were seen to be significantly more language anxious than males. One of the possible reasons of this consistency between male and female students' reading and listening scores may be the culture. Bensoussan and Zeidner (1989: 50) asserted that

The expression of anxiety may be permitted or inhibited by culture. In certain societies, the show of emotion is considered a feminine characteristic, and discouraged in males. If so, the higher anxiety levels expressed by females, especially in groups may not only have been influenced by the testing situation, but they may also have been a reflection of behavior patterns, permitted or encouraged by the culture in situations of stress.

Furthermore, Abu-Rabia (2004: 719) reported that "females were more likely to report openly their feelings of anxiety, especially in a female environment." Thus, it is more likely that male students may not report sincerely the anxiety they experienced. It is also possible that female students may compensate their anxiety by showing good performance in courses. In addition, females are usually accepted as better foreign language learners than males and are better at reading in a foreign language than males. Under these circumstances, further investigation is warranted to determine if reading and listening anxiety indeed correlated with gender.

However, when it was examined more specifically, there existed difference in terms of gender only among the first year students. Females were more anxious than males. For reading, the mean scores for males (N=13) and females (N=56) were 53,85 and 58,71, respectively. The difference was significant ( $t= 2,026$ ,  $p=, 047$  ( $p<0,05$ )). Again for listening, the mean scores for males (N=13) and females (N=56) were 96,54 and 108,84, respectively. There was a significant difference between listening anxiety and gender among first year students at the 0.05 level ( $p=,012$ ). The possible reason of it may be the effects of background variables like motivation, strategy use, visiting the target language country, prior foreign language experience, etc. In line with our assumption, female students had higher levels of reading and listening anxiety than male students. One possible basic reason behind this difference is that female students tended to use more affective strategies for language learning (Green and Oxford, 2005). Therefore, they are more delicate against the difficulties they experience during language learning in their first year in university. It may also stem from when they perceived their English less competent than that of their counterparts. Possibly, difference in terms of gender among the first year students may stem from their different background variables like high school types, age, visiting the target language country, knowing reading/listening strategies, etc.

Our next assumption was that there would be a negative relationship between language anxiety in reading/listening classes and students' academic status. That is, the first-year students would have higher levels of anxiety than the second and the third year students. The results were inconsistent. That is to say, there was no significant difference between participants' levels of listening anxiety and their academic status in university ( $p= ,497>,05$ ). Whether the learners were freshmen, sophomores, or juniors it didn't affect their scores of listening anxiety. On the other hand, it was explored that there was a significant difference between reading anxiety scores and the participants' academic status in university ( $p= ,031<,05$ ). The possible reasons behind this inconsistency between reading and listening in terms of academic status in school may be that listening skill is based on spontaneous cognitive process. Thus, the students all experience high listening anxiety without significant difference. Next, the opportunity of students' using strategies in reading process is high.

However, their strategy knowledge varies person to person. Therefore, this may cause difference. A multivariate Tukey test was used in order to determine the group or groups that cause/causes the difference. The findings elicited from the Post-Hoc Tukey test didn't reveal the group or groups that cause difference. This means that the difference between groups is meaningful but not significant. However, an in-depth investigation of the scores of the groups revealed that there was a moderate difference between reading anxiety scores of sophomores and those of juniors. In other words, students who were in the second year in ELT department had moderately higher levels of reading anxiety than those in the third year. On the other hand, with respect to listening anxiety, sophomores and juniors have lower listening anxiety than freshmen. In this regard, this finding of the study accords with those of Elkhafaifi (2005), whose study showed that there was a small, but statistically significant negative correlation between listening anxiety and the participant's year of post-secondary instruction. In other words, older and more advanced students (sophomores, juniors, and seniors) experienced lower listening anxiety than younger students (freshmen). On the other hand, it is inconsistent with those of Casado and Dereshiwsky (2001), whose study showed students' foreign language anxiety increases slightly as they progress from the first semester to the second semester. In a similar way, Onwuegbuzie et al.'s (1999) put forward that their subjects, who were at three foreign language different levels (beginning, intermediate, and advanced), displayed a fairly consistent rise in anxiety as they progress through years of study (freshmen, sophomores, juniors, seniors). Cheng (2002), on the other hand, stated that while anxiety did not increase depending on levels of writing proficiency, it did rise with year study, freshmen (first year) tending to exhibit least anxiety and juniors (third year) tending to exhibit most. Also, this finding supports those of MacIntyre and Gardner (1991a: 111), who suggested that "as experience and proficiency increase, anxiety declines in a fairly consistent manner." In terms of reading anxiety, the second year students' experiencing moderately higher levels of reading anxiety than those in the third year is consistent with that of Koroğlu (2010), whose study reported that preparatory class students experienced a significantly higher level of reading anxiety than the first year students. It can be speculated that the third year

students may show lower levels of language anxiety as they would be graduating and would feel more ready to professional life. For the results of listening anxiety, it may be that third year students' anxiety mean scores dropped slightly as they gained more familiarity with the target language, teachers' styles, and classroom activities. Another possible explanation for the findings on listening anxiety is that while first year students are still in the process of developing successful learning strategies, the second and third year students have already attained effective study skills and/or foreign language learning strategies (Saito and Samimy, 1996). It is also possible that as first year students have not had sufficient experiences in ELT department, this may play a significant role on their language anxiety. The second year students experienced higher levels of reading anxiety than those of the third year students. The possible reason behind it may be sophomores acquired more knowledge and were more aware of their own errors. Also, the teachers may have higher expectations for the intermediate and advanced class students. Thus, these students tend to experience more pressure to do well. Fear of negative evaluation may influence more strongly the first year students than the second and third year students. The goals of the learners play a crucial role on language anxiety. All in all, the conflict in the aforementioned results justifies the necessity of in-depth examining the relationship between reading/listening anxiety and grade levels of students.

The first question asked to collect qualitative data on reading and listening anxiety was how they felt in their reading and listening classes. Interestingly, a total of 18 students stated that they were whether not fully concentrated or stressful/anxious. There was no student who stated fully concentrated in reading/listening classes. The first thing that bears the mind is creating a secure, positive, and friendly classroom atmosphere. In this respect, Young (1991: 430) maintains that "a common denominator among current foreign language methods or approaches is the emphasis on creating a low anxiety classroom atmosphere." The second question was about the role of the teacher in reading and listening classes. More than half of the students (67%) claimed that teacher should be a guider and a leader in reading and listening activities rather than teaching new things. Instructors

with a good sense of humor and were friendly can reduce foreign language anxiety (Young, 1990). Price (1991: 107) suggested that “they would feel more comfortable if the instructor were more like a friend helping them to learn and less like an authority figure making them perform.” The third question was about the potential sources of anxiety in reading and listening classes. 12 students (67%) for reading and 10 subjects (56%) for listening expressed that the learners were the main causes of reading anxiety. This may arise from the irrational beliefs and fears. It may involve low self-esteem and be experienced by the students who considered themselves as having poor language ability (Young, 1991). Another possible explanation is that they may perceive themselves incompetent. For example, they may want to speak with native-like accuracy. If there is a competitive classroom environment, this will cause students to compare themselves with their peers. According to Bailey (1983) one of the sources of anxiety that the learners attributed was comparison of oneself with other students, either for their performance, or anxiety levels. Students can feel that they are alone in their anxieties and despair. When they were asked “associated with the learner, which factor do you believe may cause anxiety most?”, they overwhelmingly opted fear of failure and making mistake (72%). Vogely (1998: 73) stated that “this emotional state of mind might stem from a negative past experience or from the belief that they lack the prerequisites necessary to be a “good” language learner”. Similarly, Young suggested that instructors can alleviate language anxiety by adopting an approach that mistakes are part of the language learning process and mistakes will be made by everyone. She maintained that “students felt more at ease when the instructor did not overreact to mistakes” (1990: 9). As to the characteristics of the instructor that caused anxiety in reading and listening classes for students, half of the participant (50%) opted error correction / giving feedback as the main source of reading/listening anxiety. The instructor’s harsh manner while correcting an error may cause language anxiety. The important point is as Young stated “the issue for the student is not necessarily error correction but the *manner* of error correction—when, how often, and, most importantly, how errors are corrected” (1991: 429). Error should be corrected but by giving positive feedback. Associated with the reading / listening text, topic of the text was chosen by 11 students (61%). If the topic of the

reading or listening text is uninteresting quality, unfamiliarity, and incomprehensibility, the students may feel apprehension. Similarly, Wallace (2001) expressed that when the topic of a text was not interesting enough, it was almost impossible for the learner to read for pleasure. The next interview question was about the characteristics of the reading / listening process that provoked anxiety in reading and listening classes. Almost half of the participants (44%) chose classroom activities that produce anxiety. Most classroom activities like oral presentations, reading aloud, answering the question in a row, etc. can make students anxious. In a similar way, Koch and Terrell (1991) point out that oral skits, oral quizzes, being called on to respond orally, and oral presentations in front of the class are anxiety-producing activities. For Price (1991: 105), “greatest source of anxiety was having to speak the target language in front of their peers.” Associated with the speaker/interlocutor, speech of the interlocutor was selected by more than half of the participants (72%). When the speech is too fast, it may create the anxiety. Intonation, stress, pronunciation, and accent of the speech may produce anxiety in listening classes.

As for the reducing ways of language anxiety in reading and listening classes from the learners' perspectives, 7 out of 18 people (39%) opted the learners as the main factor to cope with reading and listening anxiety. The students believed that they could reduce the anxiety as they had stated “the learners” as the main cause of language anxiety. The learners with high self-esteem may control their anxiety. Thus, they will increase their language performances better than those of low-self-esteem. The eleventh interview question was about the characteristics of the learner to cope with anxiety in reading/listening classes. 10 students (56%) chose the cognitive strategies to cope with anxiety. 8 of them (44%) brought on the affective strategies. The students most likely tend to employ their intellectual skills like generalizing, making comparisons between languages, making associations between words, practicing, analyzing and reasoning. Affective strategies include feelings, value system, appreciation, willingness, enthusiasm, motivations (intrinsic and extrinsic), emotions, and attitudes. Language learners should be able control their attitudes and emotions and generate their own motivation about language learning. Associated

with the instructor, the instructor's giving positive feedback was focused on by 7 students (39%) and 6 subjects (33%) were of the same opinion that the instructor should create a friendly classroom environment. The last interview question was related to the factors associated with the reading and listening process to reduce anxiety in reading/listening classes. Classroom environment was the most important factor to cope with anxiety for half of the students (50%).

## **5.2. Pedagogical Implications**

The findings give rise to several pedagogical implications for reading and listening classes. At first glance, although reading seems the least anxiety-producing skill, the results of the current study demonstrated that receptive skills were anxiety provoking in Turkish ELT departments. Thus, this study proved the existence of reading and listening anxiety and reminded the instructors that even though they were receptive sides of the language, both reading and listening produced foreign language anxiety for EFL learners. In terms of raising that awareness, the study can help teachers to detect highly anxious students and to adopt a sympathetic attitude towards them.

Language teachers should raise the students' awareness about the existence of reading and listening anxiety and let them know they are not alone. In addition, the instructors should create a less stressful, friendly, and secure language learning atmosphere. This allows students to concentrate fully on reading and listening classes. This is of crucial since all the students (a total of 18) in this study asserted that they were stressful/anxious or not fully concentrated in their reading/listening classes. The teacher should be a guider and a leader rather than an authority figure in this process and be careful about the manner of error correction. S/he should emphasize that mistakes are part of language learning process. Because, the students stated that they were afraid of failure and making mistakes in reading and listening classes.

This study demonstrated that the students held themselves responsible for language anxiety. According to their responses, "the learner" was the main cause of

reading and listening anxiety. This showed that they had low self-esteem, self-confidence, and irrational beliefs on language learning. Additionally, most of them had stated their not knowing reading/listening strategies in the background questionnaire. Therefore, the teaching of specific learning strategies so that students can effectively learn from context can be of a great help.

Another source of reading/listening anxiety was topic of the text. Teachers should pay attention to selection of the topics of the texts. Moreover, students should be involved in the process of selecting the topics as unfamiliar and uninteresting topics may cause language anxiety in reading and listening classes. Another important point that should be taken into account while selecting the topics or texts is that teacher should provide students with a variety of cultural texts within an appropriate level of difficulty for “comprehensible input”. Giving some brief information about cultural topics of the texts before reading and listening is also helpful.

### **5.3. Suggestion for Future Research**

This study showed that Turkish EFL learners experienced reading and listening anxiety. Nevertheless, more work is required to further examine the functional relationship between foreign language reading and foreign language listening anxiety and background variables. The present study just took into account the variables of gender and academic status in school. It may also be conducted including more variables like age, number of years spent learning English, purpose for reading and listening, visiting the target language country, use English after school, etc. This study was conducted with the participation of 159 students from first, second, and third year. A future study may include enough participants and the fourth year students (seniors) for more reliable results. Moreover, the current study was based on only receptive skills: reading and listening. Further studies incorporating both receptive and productive skills may be carried out. Lastly, this study is limited to only English majors. Conducting a further study with the learners majoring in different languages like Spanish, French, German, etc. is necessary.

#### 5.4. Conclusions

Learning a new language puts someone one step further to keep up with this globalized world. For this reason, learning a language is a must rather than an interest or a hobby in this era. One of the most effective ways in developing a language especially in EFL context countries is to provide as much authentic comprehensible input (oral and written) as possible. Main sources of providing that kind of input are receptive language skills. If the receptive skills are well developed, the students will be more confident in language learning (Long, 1986). However, this is not such an easy task. As one of the most important affective factors in language learning process is language anxiety. For an effective and successful teaching and learning a language, language anxiety should be removed from language learning context.

In this respect, this study was conducted in ELT department of Faculty of Education in Konya Necmettin Erbakan University among 159 Turkish EFL learners to raise awareness on language anxiety in reading and listening classes. It demonstrated that reading and listening anxiety existed in ELT departments contrary to the assumption that only productive skills can be affected negatively by language anxiety. Based on the findings of the present study, several conclusions can be drawn.

Turkish EFL learners experienced a fair and similar amount of reading and listening anxiety. Their listening anxiety levels are slightly higher than those of reading anxiety as the former requires more spontaneous process of input. There was a difference only in the first year students' reading and listening anxiety scores. That is, female students had slightly higher reading and listening anxiety than male students. As for the relation between anxiety and academic status in school, there was no significant difference between listening anxiety and their academic status. However, in reading, there was a difference between sophomores and juniors. The former was more anxious than the latter.

As to the conclusions drawn from the results of qualitative data, surprisingly, a total of 18 students were whether not fully concentrated or stressful/anxious in reading and listening classes. More than half of the students claimed that teacher should be a guider and a leader in reading and listening activities rather than teaching new things. “The learner” was the main source of reading/listening anxiety for the students. They were mostly afraid of failure and making mistakes. Half of the learners complained about the manner of error correction and giving feedback. Uninteresting quality, unfamiliarity, and incomprehensibility of the topic of the text produced reading and listening anxiety among the students. They were also not satisfied with the classroom activities in reading and listening classes. For listening, speech of the interlocutor was selected by more than half of the participants as anxiety-provoking.

As for the reducing ways of language anxiety in reading and listening classes from the learners’ perspectives, nearly half of the learners (7 out of 18) chose “the learners” as the main factor to cope with reading and listening anxiety. Associated with the learner, cognitive and affective strategies were employed by the students. The instructor’s giving positive feedback and creating a friendly classroom environment were emphasized. Classroom environment was the most important factor to cope with anxiety for half of the students in terms of reading/listening process.

## REFERENCES

- Abu-Rabia, S. (2004). Teachers' role, learners' gender differences, and FL anxiety among seventh-grade students studying English as a FL. *Educational Psychology, 24*(5), 711-721.
- Abu Shawish, J. (2009). *Analysis and Assessment of Palestinian EFL Majors' Written English*. Unpublished master thesis, Sudan University of Science and Technology, Sudan.
- Abu Shawish, J., & Atea, M. (2010, October). An Investigation of Palestinian EFL Majors' Writing Apprehension: Causes and Remedies. Proceedings of the First National Conference on Improving TEFL Methods & Practices at Palestinian Universities.
- Aida, Y. (1994). Examination of Horwitz, Horwitz and Cope's construction of foreign language anxiety: The case of students of Japanese. *The Modern Language Journal, 78*(2), 155-168.
- Allwright, D., & Bailey, K. B. (1991). *Focus on the language classroom*. Cambridge: Cambridge University Press.
- Alpert, R. & Haber, R. N. (1960). Anxiety in academic achievement situations. *Journal of Abnormal and Social Psychology, 61*(2), 207-215.
- Anderson, N.J. (1999). *Exploring Second Language Reading: Issues and Strategies*. Boston, MA: Heinle & Heinle.
- Arnold, J. (2000). *Speak Easy: How to Ease Students into Oral Production*. [On-line]. Retrieved from: <http://www.hlomag.co.uk/mar03/martmar035.rtf> [June 10, 2012].
- Aydın, B. (1999). *A study of the sources of foreign language classroom anxiety in speaking and writing classes*. Unpublished doctoral dissertation, Anadolu University, Eskişehir, Turkey.

- Aydın, B., & Kuru-Gönen, İ. (2012). Listening to Students: Modification of a Reading Program Based on the Sources of Foreign Language Reading Anxiety. *Turkish Online Journal of Qualitative Inquiry*, 3(1), 20-35.
- Backman, K. M. (1976). Two measures of affective factors as they relate to progress in adult second-language learning. *Working Papers in Bilingualism*, 19, 100-122.
- Bacon, S. M. (1992). The Relationship between Gender, Comprehension, Processing Strategies, and Cognitive and Affective Response in Foreign Language Listening. *The Modern Language Journal* 76(2), 160-178.
- Bacon, S. M., & Finnemann, M. (1990, April). The Identification of Gender Differences in University Foreign- Language Students in Relation to General Language-Learning Beliefs and Beliefs Dealing with Authentic Input. Paper presented at the SLA-FLL Conference, University of Illinois, Illinois.
- Bailey, K. M. (1983). Competitiveness and anxiety in adult second language learning: Looking at and through the diary students. In H. W. Seliger, & M. H. Long (Eds.), *Classroom oriented research in second language acquisition* (pp. 67-103). Cambridge: Newbury House Publishers.
- Balemir, S. H. (2009). *Yabancı dil konuşma kaygısının nedenlerine yabancı dil konuşma kaygı düzeyi ile dil yeterlilik düzeyi arasındaki ilişki*. Yayınlanmamış yüksek lisans tezi, Bilkent Üniversitesi, Ankara.
- Bekleyen, N. (2004). Foreign Language Anxiety. *Çukurova Üniversitesi Sosyal Bilimler Enstitüsü Dergisi*. Retrieved from: <http://sosyalbilimler.cukurova.edu.tr/dergi.asp?sirano=47> [May 5, 2012].
- Bekleyen, N. (2009). Helping teachers become better English students: Causes, effects, and coping strategies for foreign language listening anxiety. *System*, 37(4), 664-675.

- Bensoussan, M., & Zeidner, M. (1989). Anxiety and achievement in a multicultural situation: The oral testing of advanced reading comprehension. *Assessment and Evaluation in Higher Education*, 14(1) 40–54.
- Bozatlı, İ. (2003). *Academic oral presentation skills instructors' perceptions of the final project presentation rating scale used in the modern languages department at Middle East Technical University*. Unpublished master thesis, Bilkent University, Ankara.
- Breakwell, G.M, Hammond, S., & Fife-Schaw, C. (1995). *Research Methods in Psychology*. London: Sage.
- Brown, H. D. (1980). *Principles of Language and Teaching*. Englewood Cliffs: NJ Prentice-Hall, USA.
- Campbell, C. M. (1999). Language Anxiety in Men and Women: Dealing with Gender Difference in the Language Classroom. In D. J. Young (Ed.), *Affect In Foreign Language and Second Language Learning* (pp. 191-215). New York: McGraw Hill.
- Campbell, C. M., & Ortiz, J. A. (1991). Helping Students Overcome Foreign Language Anxiety: A Foreign Language Anxiety Workshop. In Horwitz, E. K., & Young, D. J. (Eds.), *Language Anxiety: From Theory and Research to Classroom Implications* (pp. 153-167). Englewood Cliffs, NJ: Prentice Hall.
- Carter, R., & Nunan, D. (2002). *The Cambridge guide to teaching English to speakers of other languages*. Cambridge: Cambridge University Press.
- Casado, M. A., & Dereshiwsky, M. I. (2001). Foreign language anxiety of university students. *College Student Journal*, 35(4), 539-551.
- Casado, M. A., & Dereshiwsky, M. I. (2004). Effect of educational strategies on anxieties in the second language classroom: An exploratory comparative study between U.S. and Spanish first semester university students. *College Student Journal*, 38(1), 23-35.

- Chang, J. I. (1997). Contexts of adolescent worries: Impact of ethnicity, gender, family structure, and socioeconomic status. Paper presented at the annual meeting of NCFR Fatherhood and Motherhood in a Diverse and Changing World, Arlington, VA.
- Charlest, B. (1965). Three Studies of the Listening of Children. *Speech Monographs*, 32, 129-138.
- Chastain, K. (1975). Affective and ability factors in second language acquisition. *Language Learning*, 25(1), 153-161.
- Cheng, Y. (2002). Factors associated with foreign language writing anxiety. *Foreign Language Annals*, 35(5), 647-656.
- Cheng, Y., Horwitz, E. K., & Schallert, D. L. (1999). Language anxiety: Differentiating speaking and listening components. *Language Learning*, 49(3), 417-446.
- Clarck, A., & Trafford, J. (1996). Return to gender: boys' and girls' attitudes and achievements. *Language Learning Journal*, 14, 40-49.
- Condon, E. O. (1965). *An Analysis of the Differences Between Good and Poor Listeners in Grades Nine, Eleven, and Thirteen*, Doctoral Dissertation, Lawrence: University of Kansas, Dissertation Abstracts 26: 3106; No. 6.
- Coulombe, D. (2000). *Anxiety and beliefs of French-as-a-second-language learners at the university level*. Unpublished doctoral dissertation, Université Laval, Québec, Canada.
- Daly, J. (1991). Understanding communication apprehension: An introduction for language educators. In E. K. Horwitz, & D. J. Young (Eds.), *Language anxiety: From theory and research to classroom implications* (pp. 3-15), Englewood Cliffs, NJ: Prentice Hall.

- Daly, J. A., Kraiser, P. O., & Rogharr, L. A. (1994). Question-asking comfort: Explorations of the demography of communication in the eight-grade classroom. *Communication Education*, 43, 27-41.
- Daud, N. M., Daud, N. M., & Kassim, N. L. A. (2005). Second Language Writing Anxiety: Cause or Effect? *Malaysian Journal of ELT*, 1-19.
- Denzin, N.K. (1989). *The sociological interview*. In *The Research Act: A Theoretical Introduction to Sociological Methods*. New Jersey: Prentice Hall, 102-120.
- Devine, T. G. (1967). Listening. *Review of Educational Research*, 37(2), 152-158.
- Duker, S. (1965). Listening and Reading. *Elementary School Journal*, 65, 321-329.
- Elkhafaifi, H. (2005). Listening comprehension and anxiety in the Arabic language classroom. *The Modern Language Journal*, 89(2), 206-220.
- Ellis, G. (1999). Developing children's metacognitive awareness. In Kennedy, C. (Ed.), *Innovation and Best Practice in British ELT*. Harlow Longman, in association with the British Council.
- Ellis, G., & Sinclair, B. (1989). *Learning to learn English - a course in learner training*. Cambridge: Cambridge University Press.
- Eysenck, M. W. (1979). Anxiety, learning and memory: A reconceptualization. *Journal of Research in Personality*, 13, 363- 385.
- Felson, R. B., & Trudeau, L. (1991). Gender differences in mathematics performance. *Social Psychology Quarterly*, 54(2), 113-126.
- Foss, K., & Reitzel, A. (1991). A Relational Model for Managing Second Language Anxiety. In E. K. Horwitz & D. J. Young (Eds.), *Language anxiety: From theory and research to classroom implications*. Englewood Cliffs, NJ: Prentice Hall.

- Gardner, R. C., & MacIntyre, P. D. (1993a). A student's contributions to second language learning: Part II. Affective variables. *Language Teaching*, 26(1), 1–11.
- Gardner, R. C., Smythe, P. C., & Brunet, G. R. (1977). Intensive Second language Study: Effects on Attitudes, Motivation and French Achievement. *Language Learning*, 27, 243-261.
- Gönen, M. (2009). The relationship between listening anxiety and FL listening strategies: The case of Turkish EFL learners. Proceedings of the 5th WSEAS/IASME International Conference on Educational Technologies (EDUTE' 09).
- Grabe, W., & Stoller, F. L. (2002). *Teaching and Researching Reading*. Harlow: Pearson Education. Longman
- Green, J., & Oxford, R. L. (2005). A closer look at learning strategies, L2 proficiency, and gender. *TESOL Quarterly*, 29, 261-297.
- Gregersen, T. S., & Horwitz, E. K. (2002). Language learning and perfectionism: Anxious and non-anxious language learners' reactions to their own oral performance. *The Modern Language Journal*, 86(5), 562-570.
- Hassan, B. (2001). The Relationship of Writing Apprehension and Self-Esteem to the Writing Quality and Quantity of EFL University Students. *Mansoura Faculty of Education Journal*, 39, 1-36.
- Hembree, R. (1988). Correlates, Causes, Effects, and Treatment of Test Anxiety. *Review of Educational Research*, 58(1), 47-77
- Heritage, J. (1984). *Garfinkel and Ethnomethodology*. Cambridge: Polity Press.
- Horwitz, E. K. (1988). The beliefs about language learning of beginning university foreign language students. *Modern Language Journal*, 72(3), 283-294.

- Horwitz, E. K. (1990). Attending to the affective domain in the foreign language classroom. In S. S. Magnam (Ed.), *Shifting the instructional focus to the learner*(pp. 15-33),Middlebury, VT: Northeast Conference on the Teaching of Foreign Languages.
- Horwitz, E.K. (2008). *Becoming a language teacher: A practical guide to second language learning and teaching*. Boston: Pearson/Allyn and Bacon.
- Horwitz, E. K., Horwitz, M. B.,& Cope, J. (1986).Foreign language classroom anxiety.*The Modern Language Journal*, 70(2), 125-132.
- Horwitz, E. K.,& Young, D. J. (1991).*Language Anxiety: From theory and research to classroom implications*. Englewood Cliffs, NJ: Prentice Hall.
- Kılıç, M. (2007).*The sources and relations of foreign language listening anxiety with respect to text type and learner variables: A case study at Gaziantep University*.Unpublished master thesis, Gaziantep University, Gaziantep, Turkey.
- Kim, H. S. (2002). We talk, therefore we think? A cultural analysis of the effect of talking on thinking.*Journal of Personality and Social Psychology*, 83(4), 828-842.
- Kim, J. (2000). *Foreign Language Listening Anxiety: A study of Korean students learning English*. Dissertation Abstracts International. UMI No: 3004305.
- Kimura, H. (2008). Foreign language listening anxiety: Its dimensionality andgroup differences. *JALT Journal*, 30(2), 173-195.
- Kitano, K. (2001). Anxiety in the college Japanese language classroom.*The Modern Language Journal*, 85(4), 549-566.
- Kleinmann, H. (1977). Avoidance behaviour in adult second language acquisition.*Language Learning*, 27(1), 93–107.

- Ko, Y. A. (2010). *The Effects of Pedagogical Agents on Listening Anxiety and Listening Comprehension in an English as a Foreign Language Context*. Unpublished doctoral dissertation. Utah State University, Utah.
- Koch, A. S., & Terrell, T. D. (1991). Affective reactions of foreign language students to natural approach activities and teaching techniques. In E. K. Horwitz & D. J. Young (Eds.), *Language anxiety: From theory and research to classroom implications* (pp. 166-172). Englewood Cliffs, NJ: Prentice Hall.
- Kondo, D. S., & Ying-Ling, Y. (2004). Strategies for coping with language anxiety: the case of students of English in Japan. *ELT Journal*, 58(3), 258-265.
- Köroğlu, H. (2010). Turkish ELT students' reading anxiety and their strategies use. Unpublished master thesis. Kafkas University, Kars, Turkey.
- Krashen, S. (1982). *Principles and practice in second language acquisition*. New York: Pergamon Press.
- Krashen, S. (1985). *The input hypothesis: Issues and implications*. California: Laredo Publishing Co Inc.
- Kuru-Gönen, S. İ. (2005). The sources of foreign language reading anxiety of students in a Turkish EFL context. Unpublished master thesis. Anadolu University, Eskişehir, Turkey.
- Leki, I. (1999). Techniques for reducing second language writing anxiety. In D. J. Young (Ed.), *Affect in foreign language and second language learning* (pp. 64-88). New York: McGraw Hill.
- Lewis, R. F. (1963). *Complementing Instruction in Reading Improvement of College Students with Instruction in Auding*. Doctoral dissertation. Auburn, Ala.: Auburn University, 1963. 128 pp. (Abstract: Dissertation Abstracts 24: 3204-3205).
- Lien, H. Y. (2011). EFL learners' reading strategy use in relation to reading anxiety. *Language Education in Asia*, 2(2), 199-212.

- Liu, M. (2006). Anxiety in Chinese EFL students at different proficiency levels. *System*, 34(3), 301-316.
- Long, D.R. (1986). Listening: What's really going on in the classroom. In B. Snyder (Ed.), *Second Language Acquisition: Preparing for tomorrow* (pp. 28-37), Lincolnwood, IL: National Textbook Co.
- MacIntyre, P. D. (1995). How does anxiety affect second language learning? A reply to Sparks and Ganschow. *The Modern Language Journal*, 79(1), 90-99.
- MacIntyre, P. D. (1999). Language anxiety: A review of the research for language teachers. In D. J. Young (Ed.), *Affect in foreign language and second language learning: A practical guide to creating a low-anxiety classroom atmosphere* (pp. 24-45). Boston: McGraw-Hill College.
- MacIntyre, P. D., & Gardner, R. C. (1989). Anxiety and second language learning: Toward a theoretical clarification. *Language Learning*, 39(2), 251-275.
- MacIntyre, P. D., & Gardner, R. C. (1991a). Methods and results in the study of anxiety and language learning: A review of the literature. *Language Learning*, 41(1), 85-117.
- MacIntyre, P. D., & Gardner, R. C. (1994a). The effects of induced anxiety on three stages of cognitive processing in computerized vocabulary learning. *Studies in Second Language Acquisition*, 16(1), 1-17.
- MacIntyre, P. D., & Gardner, R. C. (1994b). The subtle effects of language anxiety on cognitive processing in the second language. *Language Learning*, 44(2), 283-305.
- Matsuda, S., & Gobel, P. (2004). Anxiety and predictors of performance in the foreign language classroom. *System*, 32, 21-36.
- May, R. (1977). *The meaning of anxiety*. New York: Washington Square Press.

- McCoy, I. R. (1979). Means to Overcome the Anxieties of Second Language Learners. *Foreign Language Annals*, 12, 185-189.
- Meji'as, H., Applebaum, R.L., Applebaum, S.J., & Trotter, R.T. (1991). Oral communication apprehension and Hispanics: an exploration of oral communication apprehension among Mexican American students in Texas. In: Horwitz, E.K., Young, D.J. (Eds.), *Language Anxiety: From Theory and Research to Classroom Implications*. (pp. 87-97). Prentice-Hall, Englewood Cliffs, NJ.
- Merç, A. (2009). The relationship between reading anxiety and listening anxiety: A study with Turkish EFL learners. In J. Arabski & A. Wojtaszek (Eds.), *Multidisciplinary perspectives on second language acquisition and foreign language learning* (pp. 287-304). Katowice: Oficyna Wydawnicza.
- Merç, A. (2010). *Foreign Language Student Teacher Anxiety*. Unpublished doctoral dissertation. Anadolu University, Eskişehir, Turkey.
- Merriam, S. B. (1998). *Qualitative research and case study applications in education*. San Francisco: Jossey-Bass.
- Nichols, P. (1991). *Social Survey Methods*. Oxford: Oxfam.
- Nunnally, J.C., & Bernstein, I.H. (1994). *Psychometric Theory*. McGraw-Hill: New York.
- Onwuegbuzie, A. J., Bailey, P., & Daley, C. E. (1999). Factors associated with foreign-language anxiety. *Applied Psycholinguistics*, 20(2), 217-239.
- Oxford, R. L. (1989). Use of language learning strategies: A synthesis of studies with implications for strategy training. *System*, 17(2), 235-247.
- Oxford, R. L. (1999). Anxiety and the language learner: New insights. In J. Arnold (Ed.), *Affect in language learning* (pp. 58-67), Cambridge: CUP

- Oxford, R. (2001). Language learning styles and strategies. M. Celce-Murcia (Ed.), *Teaching English as a Second or Foreign Language* (pp. 359-366), Boston: Heinle&Heinle.
- Oxford, R.,& Ehrman, M. (1993).Second-language research on individual differences.*Annual Review of Applied Linguistics,13*, 188-205.
- Palacios, L.M. (1998). *Foreign language anxiety and classroom environment: A study of Spanish university students*.Unpublished doctoral dissertation, The University of Texas, Austin.
- Patton, M. Q. (1990). *Qualitative Evaluation Methods*. Thousand Oaks: Sage.
- Peacock, M. (1998). The accuracy of interview data: testing Oller. *The Korea TESOL Journal, 1*(1), 11-17.
- Phillips, E. M. (1990). *The effects of anxiety on performance and achievement in an oral test of French*.Doctoral dissertation, University of Texas at Austin. Dissertation Abstracts.
- Phillips, E. M. (1992). The effects of language anxiety on student oral test performance and attitudes.*The Modern Language Journal, 76*(1), 14-26.
- Pichette, F. (2009). Second language anxiety and distance language learning. *Foreign Language Annals, 42*(1), 77-93.
- Poelmans, P. (2003). Developing second-language listening comprehension: Effects of training lower-order skills versus higher-order strategy. Retrieved from [http:// www.lotpublications.nl/publish/articles/000394/ bookpart.pdf](http://www.lotpublications.nl/publish/articles/000394/bookpart.pdf) [March 12, 2012].
- Price, M. L. (1991). The subjective experience of foreign-language anxiety: Interviews with highly anxious students. In E. K. Horwitz & D. J. Young (Eds.), *Language anxiety: From theory and research to classroom implications*(pp. 101-108). Englewood Cliffs, NJ: Prentice-Hall.

- Radnofsky, M. L., & Spielmann, G. (2001). Learning language under tension: New directions from a qualitative study. *Modern Language Journal*, 85, 259-278.
- Richards, J. C., & Schmidt, R. (2002). *Longman Dictionary of Language teaching and Applied Linguistics*. Harlow, JE: Pearson.
- Rivers, W. (1981). *Teaching Foreign Language Skills*. Chicago: The University of Chicago Press.
- Rodriguez, M. (1995). Foreign language classroom anxiety and students' success in EFL classes. *Revista Venezolana de Linguística Aplicado*, 1(1), 23-32.
- Ross, R. R. (1964). A Look at Listeners. *Elementary School Journal*, 64, 369-372.
- Rubin, J. (1994). A Review of Second Language Listening Comprehension. *The Modern Language Journal*, 78(2), 199-221.
- Saito, Y., & Samimy, K. K. (1996). Foreign language anxiety and language performance: A study of learner anxiety in beginning, intermediate, and advanced-level college students of Japanese. *Foreign Language Annals*, 29(2), 239-249.
- Saito, Y., Horwitz, E.K., & Garza, T.J. (1999). Foreign language reading anxiety. *Modern Language Journal*, 83, 202-218.
- Samimy, K. (1994). Teaching Japanese: Consideration of learners' affective variables. *Theory into Practice*, 33(1), 29-33.
- Saricoban, A. (1999). The Teaching of Listening. *The Internet TESL Journal*, 5(12). Retrieved from: <http://iteslj.org/> [January 24, 2012].
- Scovel, T. (1978). The effect of affect on foreign language learning: A review of the anxiety research. *Language Learning*, 28(1), 129-142.
- Scovel, T. (1991). The effect of affect on foreign language learning: A review of the anxiety research. In E. K. Horwitz & D. J. Young (Eds.). *Language*

- anxiety: From theory and research to classroom implications* (pp. 15-24). EnglewoodCliffs, NJ: Prentice Hall.
- Sellers, V.D. (2000). Anxiety and reading comprehension in Spanish as a foreign language. *Foreign Language Annals*, 33, 512-521.
- Sertçetin, A. (2006). *Classroom Foreign Language Anxiety among Turkish Primary School Students*. Unpublished master thesis, Uludag University, Bursa, Turkey.
- Shi, Y. Z., & Liu, Z. Q. (2006). Foreign language reading anxiety and its relationship to English achievement and gender. *Journal of PLA University of Foreign Languages*, 29, 59-65.
- Song, J. (2010). *The effects of anxiety on Korean ESL learners' reading strategy use and reading comprehension*. Unpublished master thesis, The University of Texas, Austin.
- Spielberger, C. D. (1966). Theory and research on anxiety. In C. D. Spielberger Ed.), *Anxiety and behavior* (pp. 3-20). New York: Academic Press.
- Spielberger, C.D. (1972). Anxiety as an emotional state. In Spielberger C. D. (Ed.), *Anxiety current trends in theory and research*. New York: Academic Press.
- Spielberger, C. D. (1976). The nature and measurement of anxiety. In C. D. Spielberger & R. Diaz-Guerro (Eds.), *Cross-cultural anxiety*. (Vol. 1, pp. 3-12). Washington DC: Hemisphere.
- Spielberger, C. D. (1983). *Manual for the State-Trait Anxiety Inventory (Form Y)*. Palo Alto, California: Consulting Psychologists.
- Spielmann, G., & Radnofsky, M. L. (2001). Learning language under tension: New directions from a qualitative study. *The Modern Language Learning*, 85(2), 259-278.

- Şahin, N. (2011). *A case study: Sources of English Language Reading Anxiety and Emotional Coping Strategies of 6th, 7th, and 8th Grade Primary School Learners*. Unpublished masterthesis, Gazi University, Ankara, Turkey.
- Subaşı, G. (2010). What are the Main Sources of Turkish EFL Students' Anxiety in Oral Practice? *Turkish Online Journal of Qualitative Inquiry*, 1(2) 29-45.
- Tobias, S. (1986). Anxiety and cognitive processing of instruction. In R. Schwarzer (Ed.), *Self-related cognition in anxiety and motivation*. (pp. 35-54). Hillsdale, NJ: Erlbaum.
- Urquhart, S., & Weir, C. (1998). *Reading in a Second Language: Process, Product and Practice*. London: Longman.
- Vogely, A. J. (1998). Listening comprehension anxiety: Students' reported sources and solutions. *Foreign Language Annals*, 31(1), 67-80.
- Von Worde, R. (2003). Students' perspectives on foreign language anxiety. *Inquiry*, 8(1), 1-16.
- Wallace, C. (2001). Reading. In R. Carter & D. Nunan (Eds.), *The Cambridge guide to teaching English to speakers of other languages* (pp. 21–28). Cambridge: Cambridge University Press.
- Wang, S. (2010). An Experimental Study of Chinese English Major Students' Listening Anxiety of Classroom Learning Activity at the University Level. *Journal of Language Teaching and Research*, 1(5), 562-568.
- Wilson, J. T. S. (2006). *Anxiety in Learning English as a Foreign Language: Its Associations with Student Variables, with Overall Proficiency, and with Performance on an Oral Test*. Unpublished doctoral dissertation, The University of Granada, Granada.
- Woodrow, L. (2006). Anxiety and speaking English as a second language. *RELC Journal*, 37(3), 308–328.

- Wu, H. J. (2011). Anxiety and Reading Comprehension Performance in English as a Foreign Language. *Asian EFL Journal* 13(2), 273-307.
- Young, D. J. (1986). The relationship between anxiety and foreign language oral proficiency ratings. *Foreign Language Annals*, 19(5), 439-445.
- Young, D.J. (1990). An investigation of students' perspectives on anxiety and speaking. *Foreign Language Annals*, 23(6), 539-553.
- Young, D. J. (1991). Creating a low anxiety classroom environment: What does language anxiety research suggest? *The Modern Language Journal*, 75(4), 426-437.
- Young, D. J. (1992). Language anxiety from the foreign language specialist's perspective: Interviews with Krashen, Omaggio Hadley, Terrell and Rardin. *Foreign Language Annals*, 25(2), 157-172.
- Young, D.J. (1994). New directions in language anxiety research. In A.K. Carol, (Ed.), *Faces in a crowd: The individual learner in multisection courses* (pp. 3-46). Heinle & Heinle.
- Zeidner, M. (1988). *Test anxiety: The State of the Art*. Plenum Publishers.
- Zhang, L. J. (2000). Uncovering Chinese ESL students' anxiety in a study-abroad context. *Asian Pacific Journal of Language in Education*, 3(2), 31-52.
- <http://coerll.utexas.edu/methods/modules/listening/01/questions.php>. Retrieved [June 17, 2012].
- <http://www.ef.com.tr/epi/>. Retrieved [April, 2012].

## APPENDICES

### Appendix 1

#### Foreign Language Reading Anxiety Scale (Saito, Garza, and Horwitz, 1999).

SD = Strongly disagree D = Disagree N = Neither agree or disagree A = Agree SA = Strongly agree		SD	D	N	A	SA
1	I get upset when I am not sure whether I understand what I am reading in English.	1	2	3	4	5
2	When reading English, I often understand the words but still can't quite understand what the author is saying.	1	2	3	4	5
3	When I'm reading English, I get so confused I can't remember what I am reading.	1	2	3	4	5
4	I feel intimidated whenever I see a whole page of English in front of me.	1	2	3	4	5
5	I am nervous when I am reading a passage in English when I am not familiar with the topic.	1	2	3	4	5
6	I get upset whenever I encounter unknown grammar when reading English.	1	2	3	4	5
7	When reading English, I get nervous and confused when I don't understand every word.	1	2	3	4	5
8	It bothers me to encounter words I can't pronounce while reading English.	1	2	3	4	5
9	I usually end up translating word by word when I am reading English.	1	2	3	4	5
10	By the time I get past the funny letters and symbols in English, it's hard to remember what you're reading about.	1	2	3	4	5
11	I am worried about all the new symbols I have to learn in order to read in English.	1	2	3	4	5
12	I enjoy reading English.	1	2	3	4	5
13	I feel confident when I am reading in English.	1	2	3	4	5
14	Once I get used to it, reading English is not so difficult.	1	2	3	4	5
15	The hardest part of learning English is learning to read.	1	2	3	4	5
16	I would be happy just to learn to speak English rather than having to learn to read as well.	1	2	3	4	5
17	I don't mind reading to myself, but I feel very uncomfortable when I have to read English.	1	2	3	4	5
18	I am satisfied with the level of reading ability in English that I have achieved so far.	1	2	3	4	5
19	English culture and ideas seem very foreign to me.	1	2	3	4	5
20	I have to know so much about English history and culture in order to read English.	1	2	3	4	5

## Appendix 2

### Foreign Language Listening Anxiety Scale (Kim in 2000).

	SD = Strongly disagree D = Disagree N = Neither agree or disagree A = Agree SA = Strongly agree	SD	D	N	A	SA
1	When listening to English, I tend to get stuck on one or two unknown words	1	2	3	4	5
2	I get nervous if a listening passage is read only once during English listening tests	1	2	3	4	5
3	When someone pronounces words differently from the way I pronounce them, I find it difficult to understand	1	2	3	4	5
4	When a person speaks English very fast, I worry that I might not understand all of it	1	2	3	4	5
5	I am nervous when I am listening to English if I am not familiar with the topic	1	2	3	4	5
6	It is easy to guess about the parts that I miss while listening to English	1	2	3	4	5
7	If I let my mind drift even a little bit while listening to English, I worry that I will miss important ideas	1	2	3	4	5
8	When I am listening to English, I am worried when I cannot watch the lips or facial expression of a person who is speaking	1	2	3	4	5
9	During English listening tests, I get nervous and confused when I do not understand every word	1	2	3	4	5
10	When listening to English, it is difficult to differentiate the words from one another	1	2	3	4	5
11	I feel uncomfortable in class when listening to English without the written text	1	2	3	4	5
12	I have difficulty understanding oral instructions given to me in English	1	2	3	4	5
13	It is hard to concentrate on what English speakers are saying unless I know them well	1	2	3	4	5
14	I feel confident when I am listening in English	1	2	3	4	5
15	When I am listening to English, I often get so confused I cannot remember what I have heard.	1	2	3	4	5
16	I fear I have inadequate background knowledge of some topics when listening to English	1	2	3	4	5
17	My thoughts become jumbled and confused when listening to important information in English	1	2	3	4	5
18	I get worried when I have little time to think about what I hear in English	1	2	3	4	5
19	When I am listening to English, I usually end up translating word by word without understanding the contents	1	2	3	4	5
20	I would rather not have to listen to people speak English at all	1	2	3	4	5
21	I get worried when I cannot listen to English at my own pace	1	2	3	4	5
22	I keep thinking that everyone else except me understands very well what an English speaker is saying	1	2	3	4	5
23	I get upset when I am not sure whether I understand what I am listening in English	1	2	3	4	5
24	If a person speaks English very quietly, I am worried about understanding	1	2	3	4	5
25	I have no fear of listening to English as a member of an audience	1	2	3	4	5
26	I am nervous when listening to an English speaker on the phone or when imagining a situation where I listen to an English speaker on the phone	1	2	3	4	5

27	I feel tense when listening to English as a member of a social gathering or when imagining a situation where I listen to English as a member of a social gathering	1	2	3	4	5
28	It is difficult for me to listen to English when there is even a little bit of background noise	1	2	3	4	5
29	Listening to new information in English makes me uneasy	1	2	3	4	5
30	I get annoyed when I come across words that I do not understand while listening to English	1	2	3	4	4
31	English stress and intonation seem familiar to me	1	2	3	4	5
32	When listening to English, I often understand the words but still cannot quite understand what the speaker means	1	2	3	4	5
33	It frightens me when I cannot catch a key word of an English listening passage	1	2	3	4	5

## Appendix 3

### Background Information Questionnaire

**Class:** First year / Second year/ Third year / Fourth year

**Gender:** Male / Female

**Age:**

**High School:**Regular High School/ Anatolian High School / Vocational High School  
AnatolianTeacher Training High School / Other

1. Do you like studying in ELT Department?

Yes                       No                       I'm not sure.

2. Why do you learn English?

Interest                       Job Opportunities                       Academic Career  
 Compulsory                       Social Status                       Other (.....)

3. Which aspects of language is the most important for you?

Pronunciation                       Grammar                       Communication  
 Comprehension                       Vocabulary

4. How often do you read or listen something?

Always                       Usually                       Sometimes                       Rarely  
 Never

5. Do you know Reading / Listening strategies?

Yes                       Some                       No

6. Have you heard about stress or anxiety in language learning?

Yes                       No

## Appendix 4

### Semi-Structured (Fixed-response) Interview Questions

1. How do you feel in your Reading /Listening classes?
  - Fully concentrated       Stressful / Anxious   Not fully  concentrated
2. What is the role of the instructor/teacher in Reading / Listening classes?  
 .....
3. Which component of the Reading class does cause most anxiety for you?
  - I think it results from the learner
  - I think it stems from the instructor / lecturer /mentors
  - The reading text causes anxiety
  - The reading process is the cause of anxiety
4. Which component of the Listening class does cause most anxiety for you?
  - It arises from the learner / students
  - The instructors / teachers are the reason of anxiety
  - The listening process is the main reason
  - I think the listening text does
  - The interlocutor / speaker causes most anxiety
5. Associated with the **learner**, which factor do you believe may cause anxiety most?
  - Linguistic incapability
  - Cognitive inability
  - Lack of motivation/confidence/self-esteem
  - Cultural beliefs / attitudes
  - Fear of failure/making mistake
  - Competitiveness
  - High expectations/perfectionism
  - Negative classroom experiences
6. Associated with the **instructor**, which factor do you believe may cause anxiety most?
  - Interaction with the learners / Attitudes       High expectations / Perfectionism
  - Error correction/feedback       Unsympathetic personality
  - Classroom management
7. Associated with the **reading / listening text**, which factor do you believe may cause anxiety most?
  - Unknown grammatical structures /words
  - Format of the text (clarity, length, visual aids)
  - Topic of the text (inauthenticity, unfamiliarity, lack of background information)
8. Associated with the **reading / listening process**, which factor do you believe may cause anxiety most?

- Methodology (methods, strategies, program)
  - Uncomfortable/insecure classroom environment
  - Classroom activities (public speaking, presentations)
  - Evaluation (test types, exams)
9. Associated with the speaker/interlocutor, which factor do you believe may cause anxiety most?
- Speech (pronunciation, intonation)       Gender of the speaker
  - Number of speakers      Na  Quality of the speaker
10. Which factor do you believe is more important to cope with Reading / Listening anxiety?
- The learners/studentsThe instructor  teachers
  - The reading/listeningprocess
11. Which strategy do you believe can be used successfully to reduce Reading / Listening anxiety associated with the learner?
- Cognitive strategies (positive thinking, peer-seeking)
  - Affective strategies (deep breathing, motivate yourself, try to calm down)
  - Behavioral strategies (improve language learning strategies, preparation, studying)
12. Which factor do you believe is more important to cope with Reading / Listening anxiety associated with the instructor?
- Creating friendly/secure classroom environment
  - Teaching language learning strategies
  - Raise awareness (talking about anxiety)
  - Outline course objectives regularly
  - Giving positive feedback
13. Which factor do you believe is more important to cope with the Reading / Listening anxiety associated with the reading / listening process?
- Pedagogical practices (pair and small group work)
  - Classroom environment
  - Evaluation (testing)
  - Choosing the text (to be involved in decision making process)

**T.C.**  
**NECMETTİN ERBAKAN ÜNİVERSİTESİ**  
**Eğitim Bilimler Enstitüsü Müdürlüğü**

**Özgeçmiş**

AdıSoyadı:	Mehmet KARACA
DoğumYeri:	Vezirköprü / SAMSUN
DoğumTarihi:	20.10.1986
MedeniDurumu:	Evli
<b>ÖğrenimDurumu</b>	
Derece	OkulunAdı
İlköğretim	Mehmet Paşa İlköğretim Okulu
Ortaöğretim	
Lise	Akpınar Anadolu Öğretmen Lisesi
Lisans	Hacettepe Üniversitesi, Eğitimi Fakültesi, İngiliz Dili Eğitimi
Yüksek Lisans	Necmettin Erbakan Üniversitesi, Eğitim Bilimler Enstitüsü, İngiliz Dili Eğitimi
Becerileri:	
İlgi Alanları:	Yabancı Dil Öğrencilerinde Dil Kaygısı, Özel Amaçlı İngilizce, Öğretim Teknikleri
Tel:	543-229-74-77
Adres	Toros Mahallesi Çilek Sokak B1-6 No:7 TOKİ 2. Etap Ereğli / KONYA TÜRKİYE

İmza